



# Versa-Surge Surge Suppressor for Air-Driven Diaphragm Pumps

## Metallic Construction

Quality System  
ISO9001 Certified

Environmental  
Management System  
ISO14001 Certified



See page 10  
for ATEX ratings



## Table of Contents

Surge Suppressor General Information.....	1
Product Model Nomenclature.....	2, 3
Materials and Operating Temperatures .....	3
Dimensions.....	4, 5
Installation Guide .....	6
Surge Suppressor Options .....	7
Grounding the Surge Suppressor.....	8
CE Declaration of Conformity - Machinery.....	9
CE Declaration of Conformity - ATEX & Explanation of Certification.....	10

Bedu Pompen B.V.  
Poort van Midden Gelderland Rood 10  
6666 LT HETEREN  
Tel: +31 (0)88 4802 900  
Fax: +31 (0)88 4802 901  
Web: [www.bedu.nl](http://www.bedu.nl)  
Email: [info@bedu.nl](mailto:info@bedu.nl)





Quality System  
ISO9001 Certified

Environmental  
Management System  
ISO14001 Certified



# Surge Suppressor

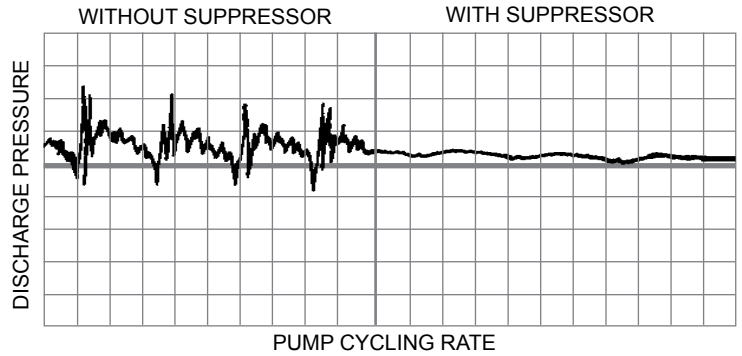

- Nearly surge-free flow.
- Steadier pressures.
- Less shock to pipes.

Air-operated diaphragm pumps offer a wide range of benefits not available in any other type of pump. However, in some applications, pulsations in the discharge flow may be undesirable. Pulsation can be virtually eliminated by installing a Versa-Matic® Surge Suppressor.

**At initial and subsequent start-ups** . . . air cushion is quickly established by liquid pressure pushing diaphragm upward, permitting entrance of air into air chamber, until the balancing air cushion causes the diaphragm to center at its mid-stroke normal operating position.

**During normal continuous operation thereafter** . . . the diaphragm always flexes at its mid-range position to absorb discharge pulsations against the adjoining air cushion already established.

**In event of change in pumped liquid pressure** . . . the air cushion pressure is automatically increased or decreased as required to compensate for the change . . . always maintaining constant volume of air cushion, and the diaphragm always operating at its mid-position.

**When liquid flow stops and liquid pressure is released** . . . the air in air chamber is also exhausted to atmosphere.

## Surge Suppressor

- Automatically maintains a constant volume of air cushion for most effective surge suppression, regardless of pump pressure.
- Automatically self-charging and self-venting to maintain most efficient air cushion pressure . . . no more precharge pressure calculations or guesswork, no manual pressurizing, no periodic pressure checking.
- Air cushion separated from product by flexible diaphragm . . . prevents product aeration.
- External visual indication provides constant evidence of performance.
- Simple to install. Attention-free.



**Models VTA1 and VTA25**  
1-inch Surge Suppressor for use with 1-inch pumps

*Air Supply connection is 1/4" NPT external pipe thread.*

Maximum Operating Pressure – 125 psi.



**Models VTA1½ and VTA40**  
1½-inch Surge Suppressor for use with 1½-inch pumps

*Air Supply connection is 1/4" NPT external pipe thread.*

Maximum Operating Pressure – 125 psi.



**Models VTA2 and VTA50**  
**Design Level 2**  
2-inch Surge Suppressor for use with 1½, 2-inch pumps

*Air Supply connection is 1/4" NPT external pipe thread.*

Maximum Operating Pressure – 125 psi.

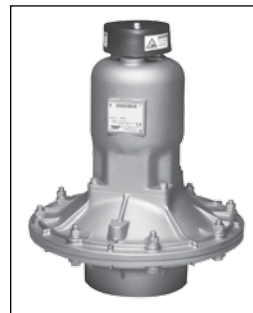

**Models VTA3 and VTA80**  
**Design Level 2**  
3-inch Surge Suppressor for use with 3-inch pumps

*Air Supply connection is 1/4" NPT external pipe thread.*

Maximum Operating Pressure – 125 psi.

# Materials of Construction:

Type Code	Diaphragm	Design Level	Wetted Parts	Porting (Internal Tapered Threads)
-----------	-----------	--------------	--------------	------------------------------------

## Surge Suppressor Model VTA1

B-1-A	B	1	A	1" NPT
H-1-A	H	1	A	1" NPT
NG-1-A	NG	1	A	1" NPT
N-1-A	N	1	A	1" NPT
S-1-A	S	1	A	1" NPT
V-1-A	V	1	A	1" NPT
B-1-SS	B	1	SS	1" NPT
F-1-SS	F	1	SS	1" NPT
H-1-SS	H	1	SS	1" NPT
NG-1-SS	NG	1	SS	1" NPT
N-1-SS	N	1	SS	1" NPT
S-1-SS	S	1	SS	1" NPT
V-1-SS	V	1	SS	1" NPT

## Surge Suppressor Model VTA1½

B-1-A	B	1	A	1½" NPT
NG-1-A	NG	1	A	1½" NPT
N-1-A	N	1	A	1½" NPT
V-1-A	V	1	A	1½" NPT
B-1-SS	B	1	SS	1½" NPT
F-1-SS	F	1	SS	1½" NPT
NG-1-SS	NG	1	SS	1½" NPT
N-1-SS	N	1	SS	1½" NPT
V-1-SS	V	1	SS	1½" NPT

## Surge Suppressor Model VTA2 Design level 2

B-2-A	B	2	A	2" NPT
I-2-A	I	2	A	2" NPT
NG-2-A	NG	2	A	2" NPT
N-2-A	N	2	A	2" NPT
S-2-A	S	2	A	2" NPT
V-2-A	V	2	A	2" NPT
B-2-CI	B	2	CI	2" NPT
I-2-CI	I	2	CI	2" NPT
NG-2-CI	NG	2	CI	2" NPT
N-2-CI	N	2	CI	2" NPT
S-2-CI	S	2	CI	2" NPT
V-2-CI	V	2	CI	2" NPT
B-2-SS	B	2	SS	2" NPT
F-2-SS	F	2	SS	2" NPT

Type Code	Diaphragm		Design Level	Wetted Parts	Porting (Internal Tapered Threads)	Porting Flange Style	Shipping Weight lbs./kg
-----------	-----------	--	--------------	--------------	------------------------------------	----------------------	-------------------------

## Surge Suppressor Model VTA25

B-1-A	B		1	A	1" BSPT		14 / 6.35
H-1-A	H		1	A	1" BSPT		14 / 6.35
NG-1-A	NG		1	A	1" BSPT		14 / 6.35
N-1-A	N		1	A	1" BSPT		14 / 6.35
S-1-A	S		1	A	1" BSPT		14 / 6.35
V-1-A	V		1	A	1" BSPT		14 / 6.35
B-1-SS	B		1	SS	1" BSPT		18 / 8.16
F-1-SS	F		1	SS	1" BSPT		18 / 8.16
H-1-SS	H		1	SS	1" BSPT		18 / 8.16
NG-1-SS	NG		1	SS	1" BSPT		18 / 8.16
N-1-SS	N		1	SS	1" BSPT		18 / 8.16
S-1-SS	S		1	SS	1" BSPT		18 / 8.16
V-1-SS	V		1	SS	1" BSPT		18 / 8.16

## Surge Suppressor Model VTA40

B-1-A	B		1	A	1½" BSPT		28 / 12.7
NG-1-A	NG		1	A	1½" BSPT		28 / 12.7
N-1-A	N		1	A	1½" BSPT		28 / 12.7
V-1-A	V		1	A	1½" BSPT		28 / 12.7
B-1-SS	B		1	SS	1½" BSPT		35 / 15.9
F-1-SS	F		1	SS	1½" BSPT		35 / 15.9
NG-1-SS	NG		1	SS	1½" BSPT		35 / 15.9
N-1-SS	N		1	SS	1½" BSPT		35 / 15.9
V-1-SS	V		1	SS	1½" BSPT		35 / 15.9

## Surge Suppressor Model VTA50 Design level 2

B-2-A	B		2	A	2" BSPT		28 / 12.7
I-2-A	I		2	A	2" BSPT		28 / 12.7
NG-2-A	NG		2	A	2" BSPT		28 / 12.7
N-2-A	N		2	A	2" BSPT		28 / 12.7
S-2-A	S		2	A	2" BSPT		28 / 12.7
V-2-A	V		2	A	2" BSPT		28 / 12.7
B-2-CI	B		2	CI	2" BSPT		35 / 15.9
I-2-CI	I		2	CI	2" BSPT		35 / 15.9
NG-2-CI	NG		2	CI	2" BSPT		35 / 15.9
N-2-CI	N		2	CI	2" BSPT		35 / 15.9
S-2-CI	S		2	CI	2" BSPT		35 / 15.9
V-2-CI	V		2	CI	2" BSPT		35 / 15.9
B-2-SS	B		2	SS	2" BSPT		35 / 15.9
F-2-SS	F		2	SS	2" BSPT		35 / 15.9

# Materials of Construction continued:

## Surge Suppressor Model VTA2 Design level 2, continued

Type Code	Diaphragm	Design Level	Wetted Parts	Porting (Internal Tapered Threads)	Porting Flange Style
NG-2-SS	NG	2	SS	2" NPT	
N-2-SS	N	2	SS	2" NPT	
V-2-SS	V	2	SS	2" NPT	
I-2-HC	I	2	HC	2" NPT	
NG-2-HC	NG	2	HC	2" NPT	
N-2-HC	N	2	HC	2" NPT	
V-2-HC	V	2	HC	2" NPT	

## Surge Suppressor Model VTA50 Design level 2, continued

Type Code	Diaphragm	Design Level	Wetted Parts	Porting (Internal Tapered Threads)	Porting Flange Style	Shipping Weight lbs./kg
NG-2-SS	NG	2	SS	2" BSPT		35 / 15.9
N-2-SS	N	2	SS	2" BSPT		35 / 15.9
V-2-SS	V	2	SS	2" BSPT		35 / 15.9
I-2-HC	I	2	HC	2" BSPT		35 / 15.9
NG-2-HC	NG	2	SS	1½" BSPT		35 / 15.9
N-2-HC	N	2	HC	1½" BSPT		35 / 15.9
V-2-HC	V	2	HC	1½" BSPT		35 / 15.9

## Surge Suppressor Model VTA3 Design level 2

B-2-A	B	2	A	3" NPT	3" ANSI Style
I-2-A	I	2	A	3" NPT	3" ANSI Style
NG-2-A	NG	2	A	3" NPT	3" ANSI Style
N-2-A	N	2	A	3" NPT	3" ANSI Style
V-2-A	V	2	A	3" NPT	3" ANSI Style
B-2-CI	B	2	CI	3" NPT	3" ANSI Style
I-2-CI	I	2	CI	3" NPT	3" ANSI Style
NG-2-CI	NG	2	CI	3" NPT	3" ANSI Style
N-2-CI	N	2	CI	3" NPT	3" ANSI Style
V-2-CI	V	2	CI	3" NPT	3" ANSI Style
B-2-SS	B	2	SS	3" NPT	3" ANSI Style
NG-2-SS	NG	2	SS	3" NPT	3" ANSI Style
N-2-SS	N	2	SS	3" NPT	3" ANSI Style
V-2-SS	V	2	SS	3" NPT	3" ANSI Style

## Surge Suppressor Model VTA80 Design level 2

B-2-A	B	2	A	3" BSPT	PN10 80 mm DIN	89 / 40.4
I-2-A	I	2	A	3" BSPT	PN10 80mm DIN	89 / 40.4
NG-2-A	NG	2	A	3" BSPT	PN10 80mm DIN	89 / 40.4
N-2-A	N	2	A	3" BSPT	PN10 80mm DIN	89 / 40.4
V-2-A	V	2	A	3" BSPT	PN10 80mm DIN	89 / 40.4
B-2-CI	B	2	CI	3" BSPT	PN10 80mm DIN	109 / 49.4
I-2-CI	I	2	CI	3" BSPT	PN10 80mm DIN	109 / 49.4
NG-2-CI	NG	2	CI	3" BSPT	PN10 80mm DIN	109 / 49.4
N-2-CI	N	2	CI	3" BSPT	PN10 80mm DIN	109 / 49.4
V-2-CI	V	2	CI	3" BSPT	PN10 80mm DIN	109 / 49.4
B-2-SS	B	2	SS	3" BSPT	PN10 80mm DIN	105 / 47.6
NG-2-SS	NG	2	SS	3" BSPT	PN10 80mm DIN	105 / 47.6
N-2-SS	N	2	SS	3" BSPT	PN10 80mm DIN	105 / 47.6
V-2-SS	V	2	SS	3" BSPT	PN10 80mm DIN	105 / 47.6

**Meaning of Abbreviations:**

A = Aluminum	H = Hytrel®	S = Santoprene®
B = Nitrile	I = EPDM	V = FKM (Fluorocarbon)
CI = Cast Iron	N = Neoprene	SS = Stainless Steel
F = FDA White Nitrile	NG = Neoprene Backup/PTFE Overlay	HC = Alloy C

Kit available to convert to top porting

\* Most other types available in dual ported design. See price book or consult factory for details.

Hytrel® are registered trademarks of E.I. du Pont. Santoprene® is a registered trademark of Exxon Mobil Corp. Versa-Matic is a registered trademark of Warren Rupp, Inc.

MATERIALS	Operating Temperatures	
	Maximum	Minimum
<b>NITRILE:</b> General purpose, oil-resistant. Shows good solvent, oil, water and hydraulic fluid resistance. Should not be used with highly polar solvents like acetone and MEK, ozone, chlorinated hydrocarbons and nitro hydrocarbons.	190°F 88°C	-10°F -23°C
<b>NEOPRENE:</b> All purpose. Resistant to vegetable oils. Generally not affected by moderate chemicals, fats, greases and many oils and solvents. Generally attacked by strong oxidizing acids, ketones, esters, nitro hydrocarbons and chlorinated aromatic hydrocarbons.	200°F 93°C	-10°F -23°C
<b>HYTREL®:</b> Good on acids, bases, amines, and glycols at room temperature.	220°F 104°C	-20°F -29°C
<b>VIRGIN PTFE:</b> Chemically inert, virtually impervious. Very few chemicals are known to chemically react with Teflon®, molten alkali metals, turbulent liquid or gases, fluorine and a few fluoro-chemicals such as chlorine trifluoride or oxygen difluoride which readily liberate free fluorine at elevated temperatures.	220°F 104°C	-35°F -37°C
<b>FKM:</b> Shows good resistance to a wide range of oils and solvents; especially all aliphatic, aromatic and halogenated hydrocarbons, acids, animal and vegetable oils. Hot water or hot aqueous solutions (over 70° F) will attack FKM.	350°F 177°C	-40°F -40°C
<b>EPDM:</b> Shows very good water and chemical resistance. Has poor resistance to oil and solvents, but is fair in ketones and alcohols.	280°F 138°C	-40°F -40°C
<b>SANTOPRENE®:</b> Injection molded thermoplastic elastomer with no fabric layer. Long mechanical flex life. Excellent abrasion resistance.	275°F 135°C	-40°F -40°C
<b>STAINLESS STEEL:</b> CF-8M equal to or exceeding ASTM specification A743 for corrosion resistant iron chromium, iron chromium nickel, and nickel based alloy castings for general applications. Commonly referred to as 316 Stainless Steel in the pump industry.		
<b>ALLOY C:</b> CW-12MW equal to or exceeding ASTM A494 specification for nickel and nickel alloy castings.		

For specific applications, always consult the Versa-Matic® "Chemical Resistance Chart".

 II 2 G c T5  
 II 3/2 G c T5  
 II 2 D c T100°C

See page 10 for ATEX Explanation of Type Examination Certificate.

## Model VTA1

Air Inlet  
 1/4" NPT (external) fitting  
 FLUID Port - 1" NPT

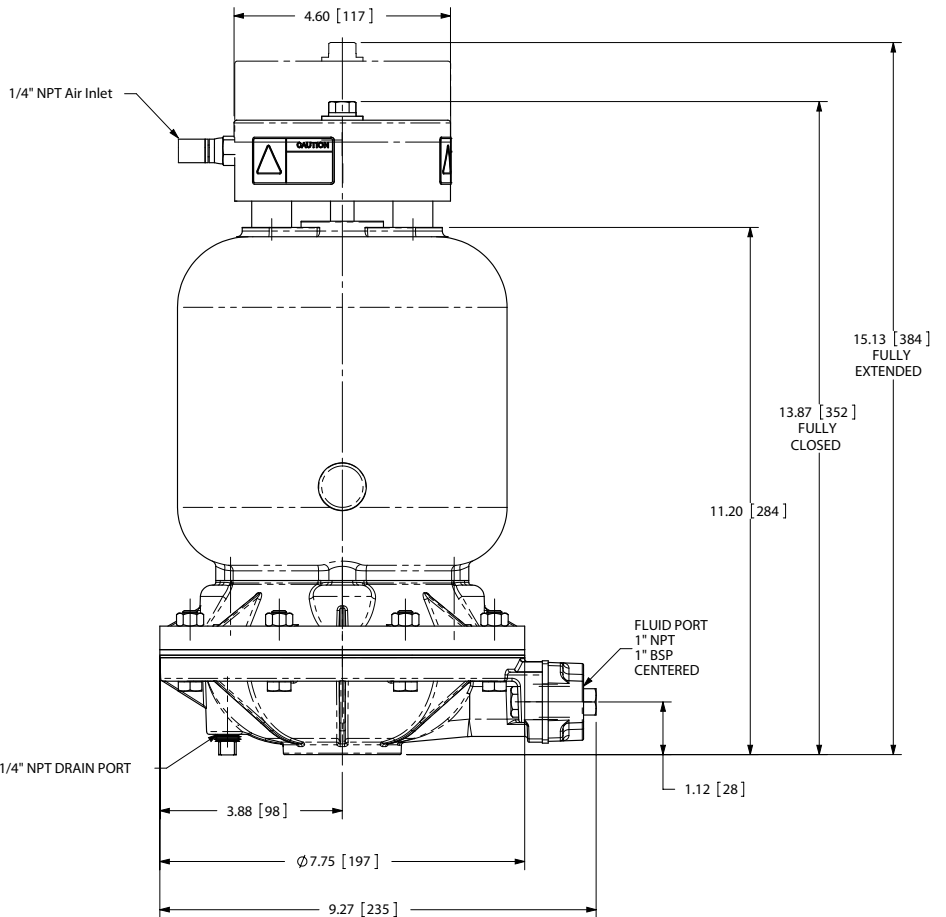

## Model VTA25

Air Inlet  
 1/4" NPT (external) fitting  
 FLUID Port - 1" BSP tapered thread

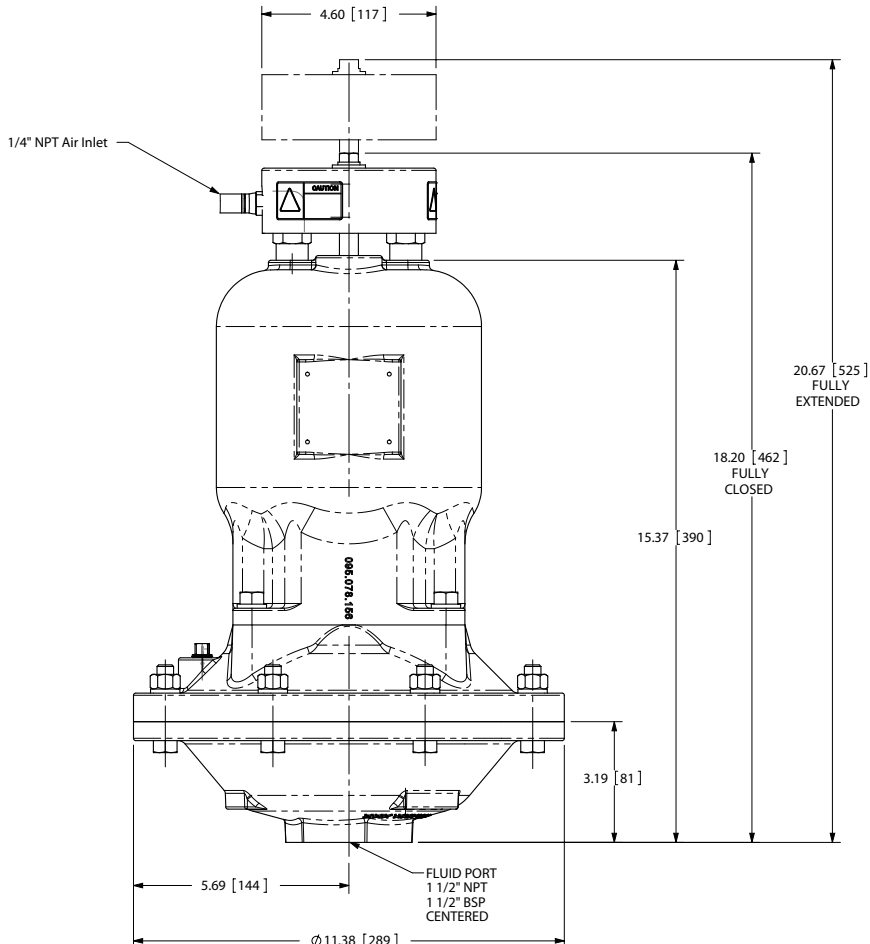

## Model VTA1 1/2

Air Inlet  
 1/4" NPT (external) fitting  
 FLUID Port - 1 1/2" NPT

## Model VTA40

Air Inlet  
 1/4" NPT (external) fitting  
 FLUID Port - 1 1/2" BSP tapered thread

All Dimensions ± .13" (3mm)

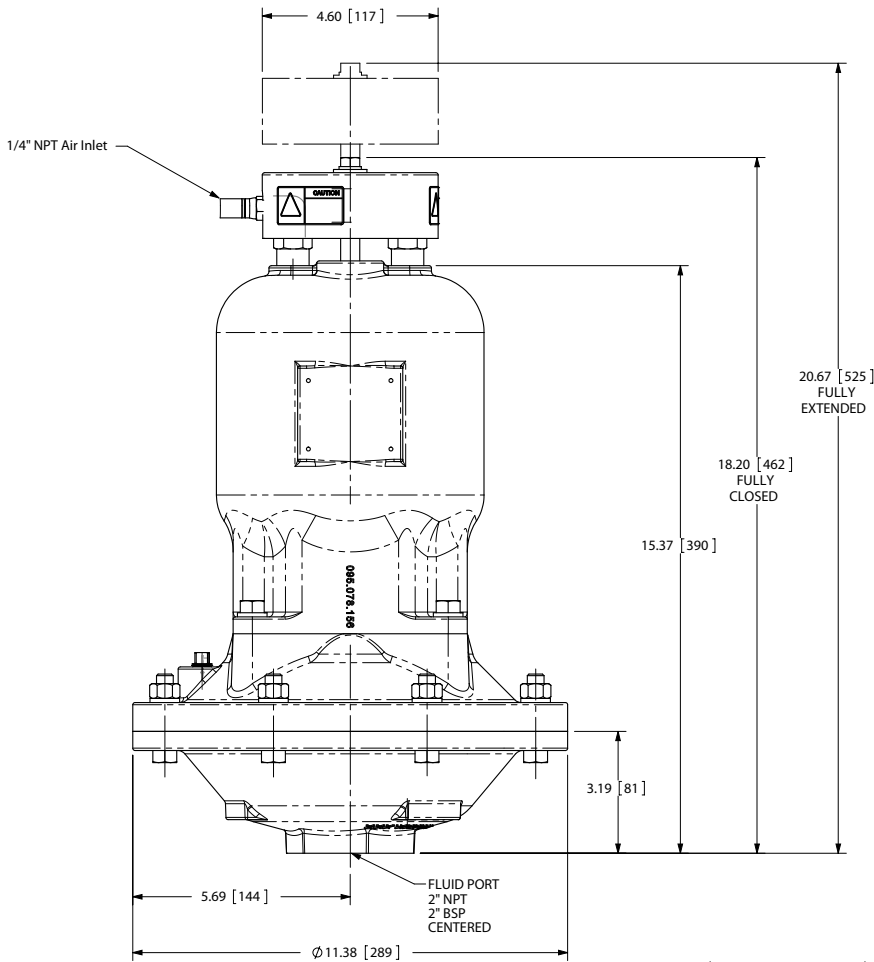

## Model VTA2

### Design Level 2

Air Inlet

1/4" NPT (external) fitting

2" NPT Fluid Port

## Model VTA50

### Design Level 2

Air Inlet

1/4" NPT (external) fitting

2" BSP(Tapered) Fluid Port

Port

## Model VTA3

### Design Level 2

Air Inlet

1/4" NPT (external) fitting

FLUID Port

## Model VTA80

### Design Level 2

Air Inlet

1/4" NPT (external) fitting

FLUID Port

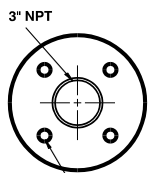
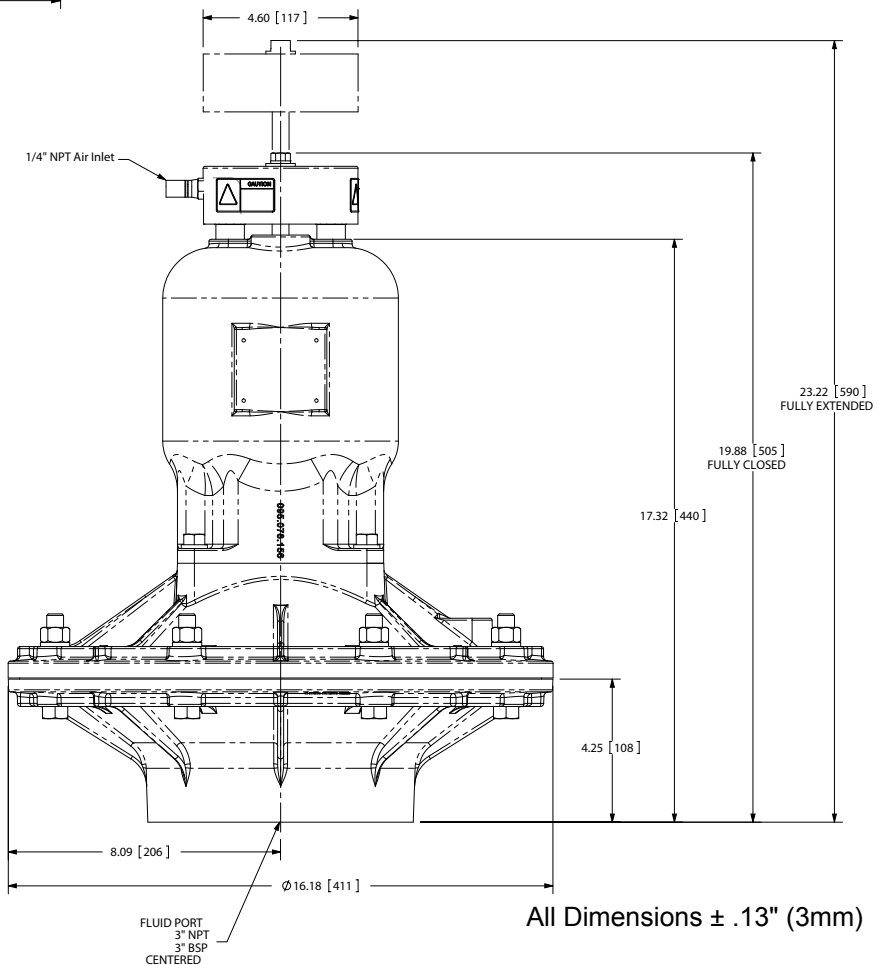

3" 150# FFANSI-style flange  
5/8-11 unc. 2B  
4 holes equally spaced on  
a 6" diameter bolt circle

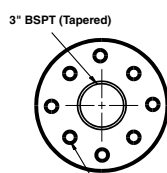

PN10 80mm DIN Flange  
M16x2 Ø holes on a  
160mm diameter Bolt Circle

All Dimensions ± .13" (3mm)

# INSTALLATION GUIDE

## Top Discharge Ball or Flap Valve Unit



Available from Versa-Matic

- ① Surge Suppressor
- ② Filter/Regulator
- ③ Lubricator
- ④ Air Dryer

	<p><b>CAUTION</b></p> <p>The air exhaust should be piped to an area for safe disposition of the product being pumped, in the event of a diaphragm failure.</p>
--	--

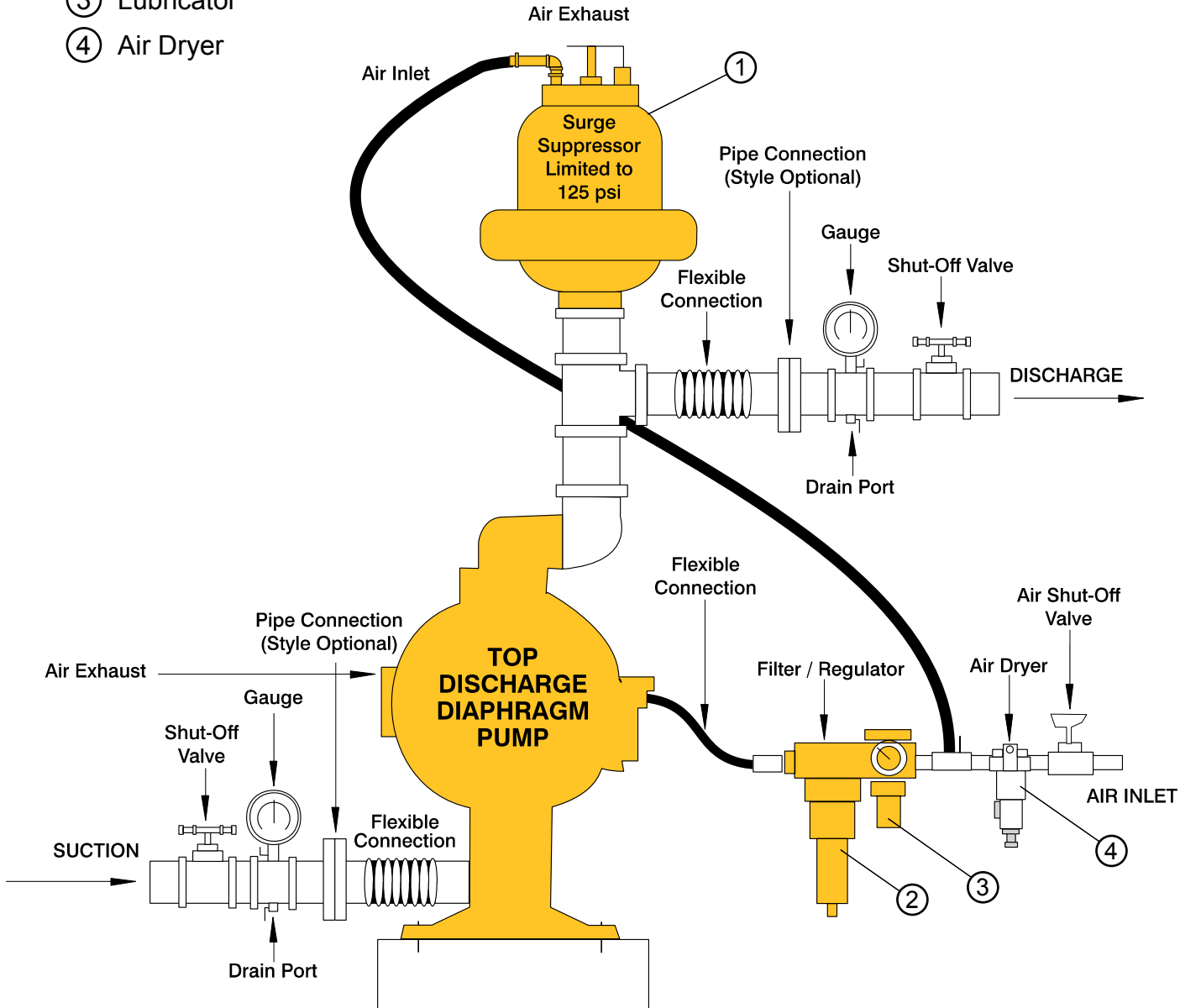

# Surge Suppressor Options

	Model & Description	Max. Pressure	Air Inlet Size	Liquid Inlet Size	Dimensions inches (mm)	Available Wetted Materials															
						Chamber				Diaphragm											
						AL	SS	CI	HC	N	B	V	I	NT	S						
	<b>VTA1</b> Designed for 1" pumps.	125 psi 8.6 bar Self-charging. Self-venting.	1/4" NPT (external thread)	1" NPT	13 5/8" to 15 1/8" height (346mm to 384mm) 9" diameter (229mm) NPT(F)																
	<b>VTA25</b> Designed for 1" pumps.	125 psi 8.6 bar Self-charging. Self-venting.	1/4" NPT (external thread)	1" BSPT (tapered internal thread)	13 5/8" to 15 1/8" height (346mm to 384mm) 9" diameter (229mm) NPT(F)																
	<b>VTA1 1/2</b> Designed for 1" and 1 1/2" pumps.	125 psi 8.6 bar Self-charging. Self-venting.	1/4" NPT (external thread)	1 1/2" NPT (internal thread)	19 7/8" to 21. 3/8" height (505mm to 543mm) 10 1/2" diameter (267mm) NPT(F)																
	<b>VTA40</b> Designed for 1" and 1 1/2" pumps.	125 psi 8.6 bar Self-charging. Self-venting.	1/4" NPT (external thread)	1 1/2" BSPT (tapered internal thread)	19 7/8" to 21. 3/8" height (505mm to 543mm) 10 1/2" diameter (267mm) NPT(F)																
	<b>VTA2</b> Design Level 2 Designed for 1 1/2 and 2" pumps.	125 psi 8.6 bar Self-charging. Self-venting.	1/4" NPT (external thread)	2" NPT (internal thread)	20 1/4" to 23 3/16" height (514mm to 589mm) 12 1/2" diameter (317mm) NPT(F)																
	<b>VTA50</b> Design Level 2 Designed for 1 1/2 and 2" pumps.	125 psi 8.6 bar Self-charging. Self-venting.	1/4" NPT	2" BSPT (tapered internal thread)	20 1/4" to 23 3/16" height (514mm to 589mm) 12 1/2" diameter (317mm) NPT(F)																
	<b>VTA3</b> Design Level 2 Designed for 3" and 4" pumps.	125 psi 8.6 bar Self-Charging. Self-venting.	1/4" NPT	3" 150# Ansi-style flange or 3" NPT internal thread	20 1/8" to 23 1/8"m height (511mm to 587mm) 16 3/16" diameter (411mm) NPT(F)																
	<b>VTA80</b> Design Level 2 Designed for 3" and 4" pumps.	125 psi 8.6 bar Self-Charging. Self-venting.	1/4" NPT	3" BSPT (tapered internal thread) or 80mm DIN-style Flange	20 1/8" to 23 1/8"m height (511mm to 587mm) 16 3/16" diameter (411mm) NPT(F)																

AL= Aluminum  
B = Nitrile  
CI = Cast iron

E = EPDM  
N = Neoprene  
NT= Overlay, Neoprene with Virgin PTFE

T = Virgin PTFE  
V = FKM (Fluorocarbon)  
S = Santoprene®

HC= Alloy C  
SS= Alloy 316 stainless steel



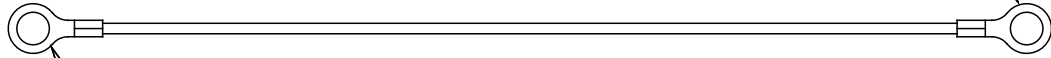

# Grounding The Surge Suppressor

One eyelet end is fastened to the surge suppressor hardware.

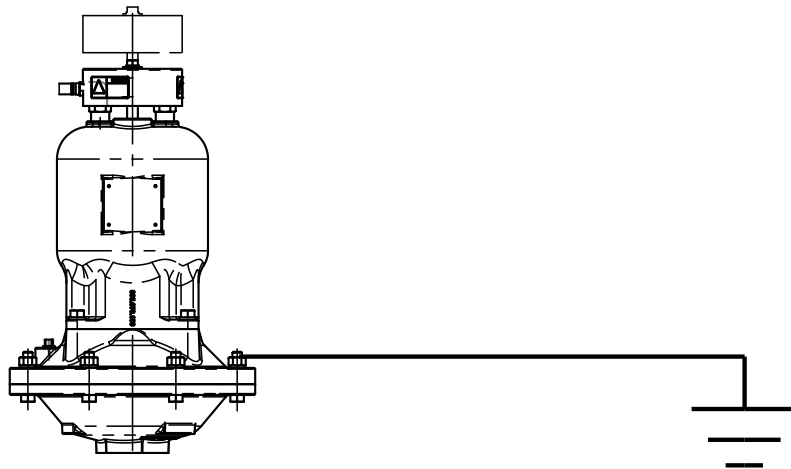

The other end is installed to a true earth ground.



	<p><b>! WARNING</b></p> <p><i>Take action to prevent static sparking. Fire or explosion can result, especially when handling flammable liquids. The pump, piping, valves, containers or other miscellaneous equipment must be grounded.</i></p>
---	---

This optional 8 foot long (244 centimeters) Ground Strap (920-025-000) is available for easy ground connection.

To reduce the risk of static electrical sparking, this surge suppressor must be grounded. Check the local electrical code for detailed grounding instruction and the type of equipment required.



## Declaration of Conformity

**Manufacturer:**

**Versa-Matic<sup>®</sup>, Warren Rupp, Inc., 800 N. Main Street, P.O. Box 1568,  
Mansfield, Ohio, 44901-1568 USA**

Certifies that Air-Operated Double Diaphragm Pump Series:  
Non-Metallic E Series, VTA Series Metallic Surge Suppressors and  
VDA Non-Metallic Surge Dampeners comply with the European Community  
Directive 2006/42/EC on Machinery, according to Annex VIII. This product  
has used Harmonized Standard EN 809, Pumps and Pump Units  
for Liquids - Common Safety Requirements, to verify conformance.

David Roseberry  
Signature of authorized person

David Roseberry  
Printed name of authorized person

Revision Level: C

October 17, 2007

Date of issue

Engineering Manager

Title

May 27, 2010

Date of revision

**IDEX**  
FLUID & METERING

CE

Declaration of Conformity

Declaration of Conformity



# Declaration of Conformity ATEX 95

In accordance with Directive 94/9/EC, Annex III  
Equipment intended for use in potentially explosive environments.

**MANUFACTURER:**

Versa-Matic®, Warren Rupp, Inc.  
A Unit of IDEX Corporation  
800 North Main Street  
P.O. Box 1568  
Mansfield, OH 44901-1568 USA

**APPLICABLE STANDARDS:**

94/9/EC  
EN13463-1: 2001, EN13463-5: 2003  
For potentially explosive environments

**MODELS:**

**Metal Surge Suppressors Series:**  
Versa-Surge Brand VTA Models

II 2 G T5  
II 3/2 G T5  
II 2 D T100°C  
**Type Examination Certificate**  
**KEMA 09ATEX0073 CE**



**Air-Operated Double Diaphragm  
Non-metallic Conductive Acetal  
Pump Model: E6**

II 1 G c T5  
II 3/1 G c T5  
II 1 D c T100°C  
**Type Examination Certificate**  
**KEMA 09ATEX0071 X**  
**CE 0344**



**Versa-Surge**

**DATE/APPROVAL/TITLE:**  
27 May 2010

David Roseberry, Engineering Manager