

# VAL, SC

## Vertical Submerged Pumps

**BEDU**  
POMPEN



### Construction

Vertical column sump pumps, with motor in dry installation and with pump body submerged in the liquid handled (without suction line or foot valve).

**Impeller** - VAL: free-flow impeller (vortex or recessed impeller).  
- SC: open impeller.

**Connection** - VAL 30, SC 30, SC 50: threaded port ISO 228 (BS 2779).  
- VAL 65: flange with plain face oval threaded counter-flange UNI 2245, PN 2,5.

### Applications

For draining a basin or a sump with domestic or industrial sewage. For slightly dirty waste water, for liquids which are non-aggressive for the pump materials.

### Operating conditions

Liquid temperature up to 40 °C.

Ambient temperature up to 40 °C.

Continuous duty.

Maximum size of solids: VAL 30 = 25 mm; VAL 65 = 50 mm;  
SC 30 = 3 mm; SC 50 = 6 mm.

### Motor

2-pole induction motor, 50 Hz ( $n \approx 2900$  rpm).

**VAL -SC**: three-phase 230/400 V  $\pm 10\%$ .

**VALM-SCM**: single-phase 230 V  $\pm 10\%$ , with thermal protector.

Insulation class F.

Protection IP 54.

**Classification scheme IE3 for three-phase motors from 0,75 kW.**

Constructed in accordance with: EN 60034-1; EN 60034-30-1.  
EN 60335-1, EN 60335-2-41.

### Special features on request

- Other voltages.
- Frequency 60 Hz (as per 60 Hz data sheet).
- Protection IP 55.
- Bronze bearing bush (for liquid up to 100 °C).
- Higher ambient temperatures.

### Materials

Components	VAL	SC
Pump casing Lower bearing housing*	Cast iron GJL 200 EN 1561	Cast iron GJL 200 EN 1561
Impeller	Brass P-Cu Zn 40 Pb 2 UNI 5705 for VAL 30	Brass P-Cu Zn 40 Pb 2 UNI 5705
	Cast iron GJL 200 EN 1561 for VAL 65	
Shaft	Steel C 40 UNI 7231	
Bearing bush	TecnoPolymer	
Shaft sleeve	Chromate bronze for VAL 65	-

\* Not existing for VAL 30.

### Characteristic curves $n \approx 2900$ rpm

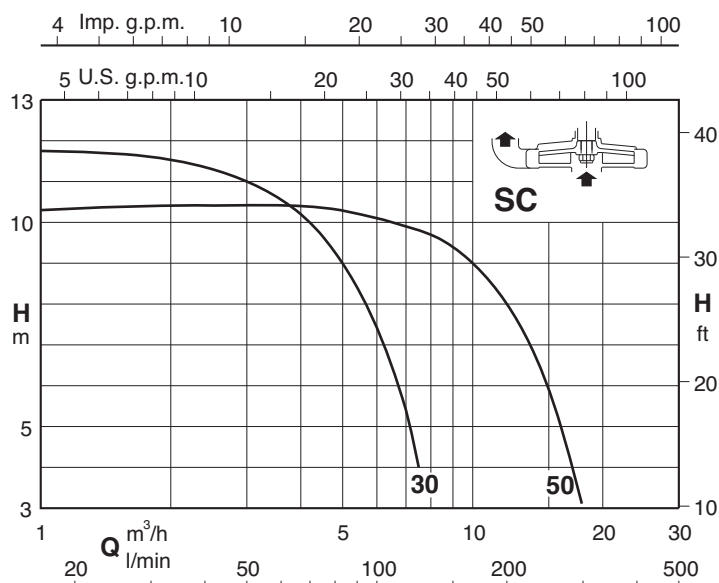
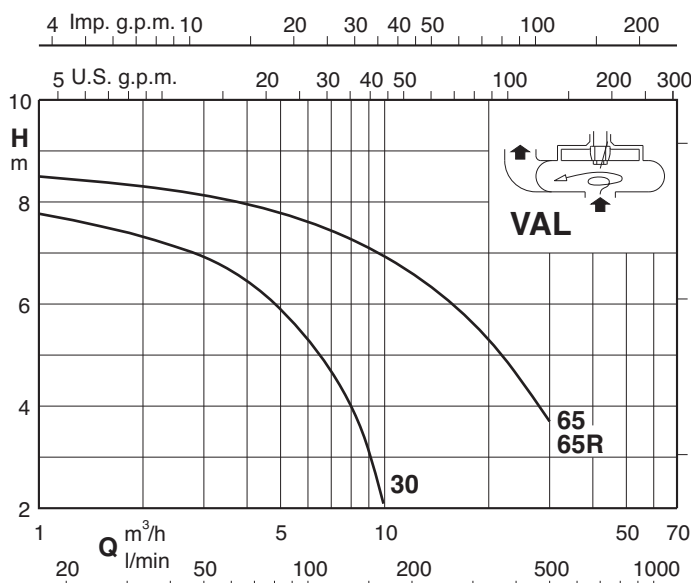

72.869.C

### Performance $n \approx 2900$ rpm

3 ~	230V 400V		1 ~	230V		P <sub>2</sub>		Q m <sup>3</sup> /h l/min	H																		
	A	A		A	kW	kW	HP		3	3,5	4	4,5	5	5,5	6	6,5	7	7,5	8	9	10	12	14	16	18	20	25
VAL 30/A	2,3	1,3	VALM 30/A	3,6	0,63	0,45	0,6	50	58,3	66,6	75	83,3	91,6	100	108	116	125	133	150	166	200	233	266	300	333	416	500
VAL 65/A	7,5	4,3				1,5	2		6,7	6,5	6,2	5,9	5,6	5,3	5	4,7	4,3	4	3	2							
VAL 65-R/B	9,15	5,3				2,2	3												7,1	6,9	6,6	6,3	6	5,6	5,3	4,5	3,7
SC 30/A	2,3	1,3	SCM 30/A	2,8	0,47	0,37	0,5	11	10,6	10,2	9,6	9	8,3	7,4	6,5	5,4	4										
SC 50/A	2,3	1,3	SCM 50/A	3,6	0,69	0,45	0,6					10,3	10,2	10,1	10	9,9	9,8	9,7	9,4	9	8	6,7	5	3			

P1 Max. power input.

P2 Rated motor power output.

H Total head in m.

Tolerances according to UNI EN ISO 9906:2012

### Dimensions and weights

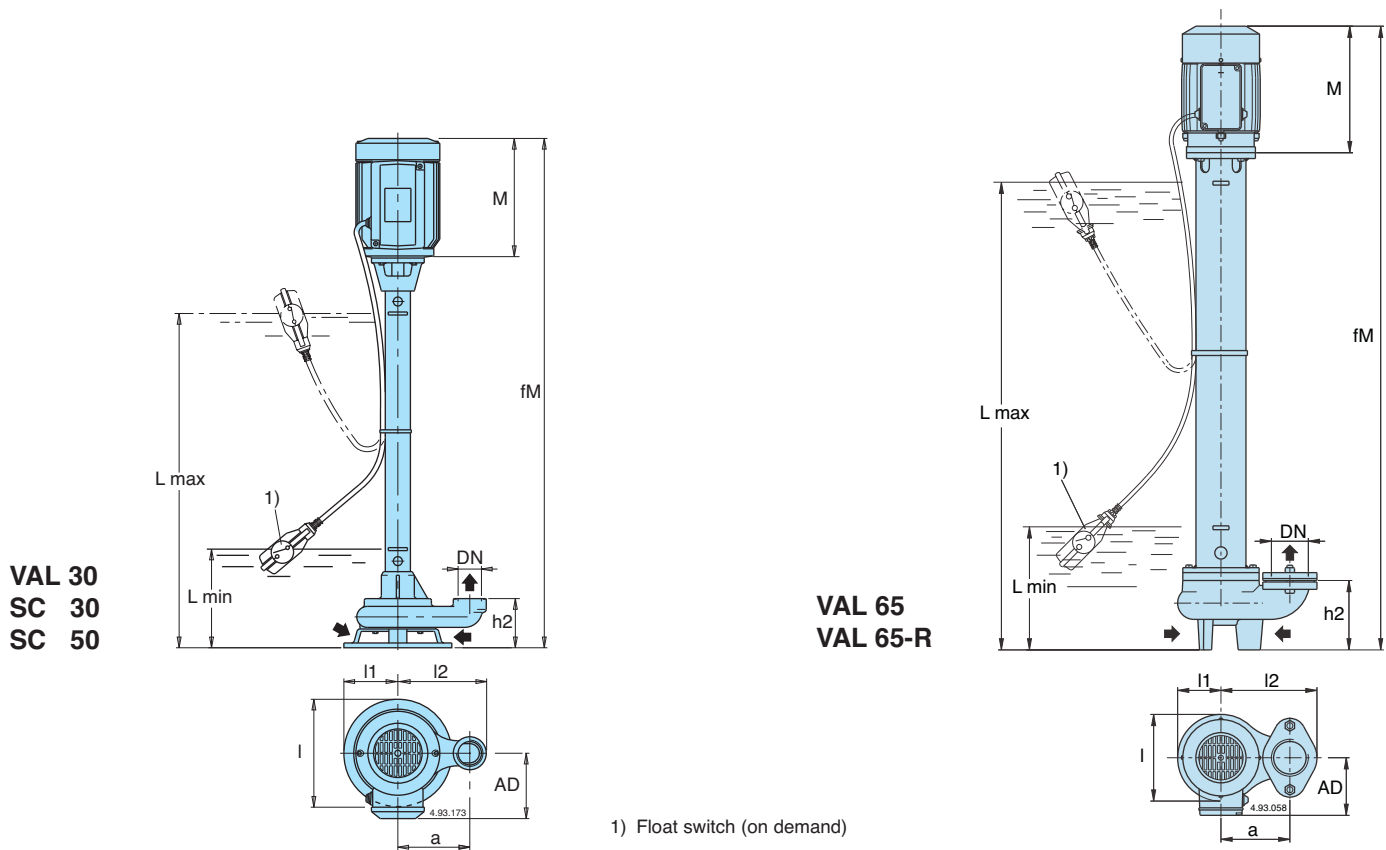

TYPE	DN ISO 228	mm										kg	
		fM	M	h2	AD	a	L min	L max	l	l1	l2		
VAL 30/750/A	G 1 1/4	1025	200	82	111	120	150	750	180	90	148	17,8	
VAL 30/1000/A		1275						1000					19,5
VAL 65/1000/A		1245						950					40
VAL 65/1500/A	G 2 1/2	1745	235	140	135	140	250	1450	175	88	195	48	
VAL 65/2000/A		2245						1950					56
VAL 65/2500/A		2745						2450					64
VAL 65/1000-R/B	G 2 1/2	1285	275	140	135	140	250	950	175	88	195	43	
VAL 65/1500-R/B		1785						1450					51
VAL 65/2000-R/B		2285						1950					59
VAL 65/2500-R/B	2785	2450	67										
SC 30/500/A	G 1 1/4	765	200	105	111	100	200	455	132	65	127	17,4	
SC 30/750/A		1015						705					19,6
SC 30/1000/A		1265						955					21,8
SC 30/1250/A	G 2	1515	200	120	111	120	215	1205	173	86	157	24	
SC 50/500/A		780						470					18,5
SC 50/750/A		1030						720					20,7
SC 50/1000/A	G 2	1280	200	120	111	120	215	970	173	86	157	22,9	
SC 50/1250/A		1530						1220					25,1

### Characteristic curves $n \approx 2900$ rpm

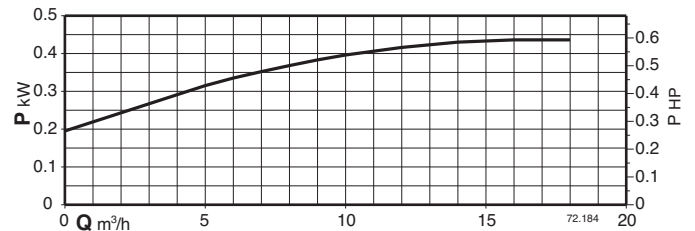
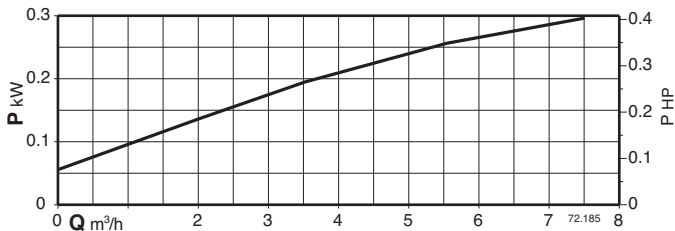
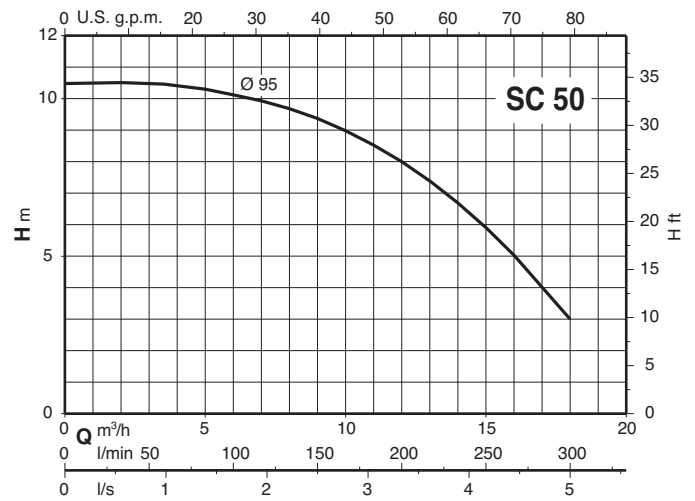
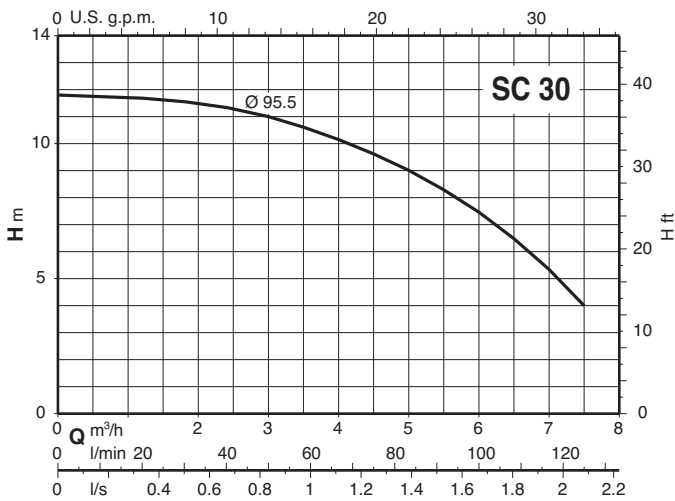
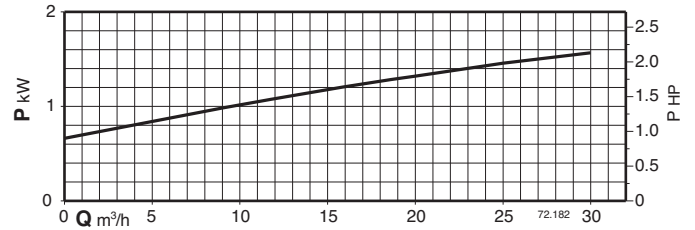
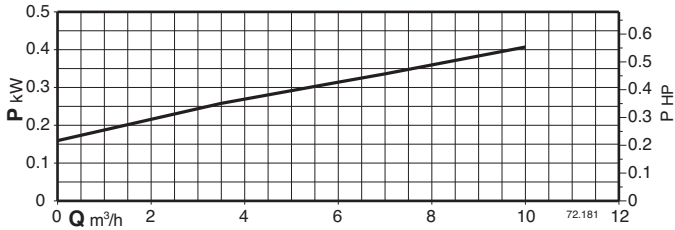
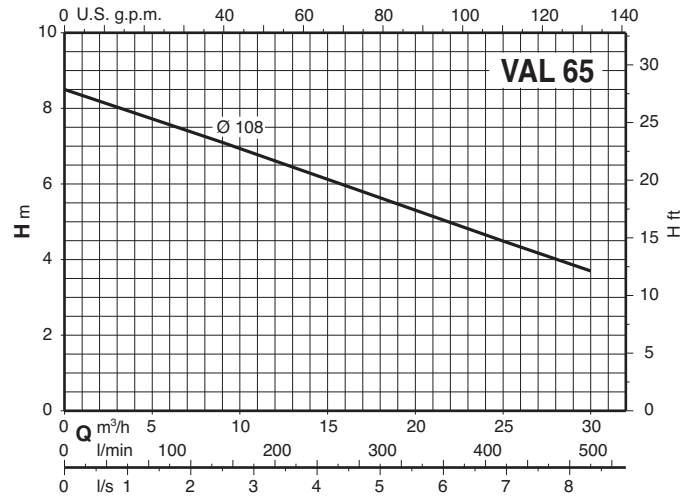
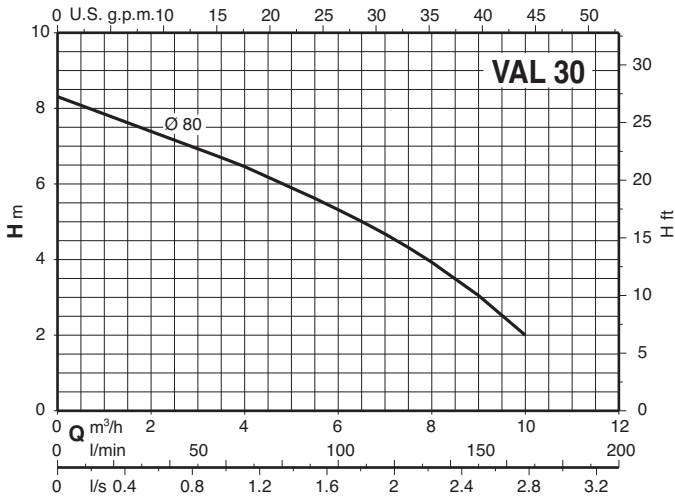

### Features

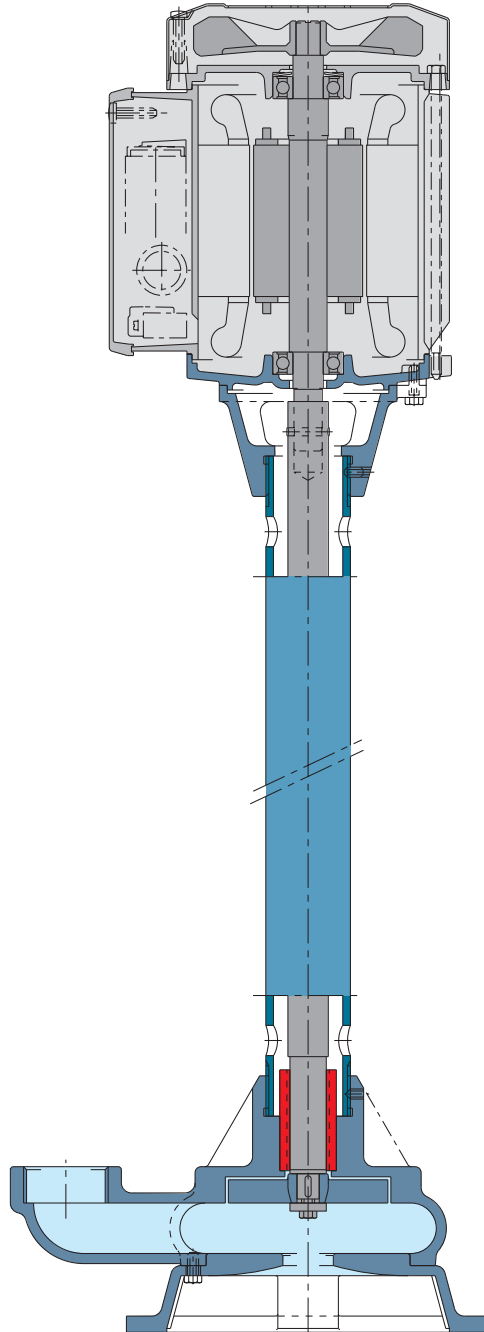

#### **Range**

The high number of pumps in the range can meet the widest range of services required by the user.

#### **Construction with no mechanical seal**

The absence of a mechanical seal minimizes the need for maintenance of the pumps.

#### **Float switch**

The pumps can be fitted with a float switch, eliminating the need for level control systems.