

Heavy duty submersible drainage pumps US 73 H and US 103 H for hot water operation



Application

The heavy duty centrifugal submersible drainage pumps US 73 and 103 HE/HES are suitable for dealing with very contaminated water and capable of handling solids up to 30 mm particle size without stones. These pumps can be used wherever **wastewater up to 194°F (90°C)** is involved, such as in laundries or automatic laundrettes, or in industrial dishwashers and washing machines or for the emergency overflow of heating systems.

This range of pumps is suitable for stationary and portable use. For easy removal of the pumps from deep sumps we recommend the use of our guide rail systems which provide ease of maintenance and inspection. A controllable oil chamber and wear-resistant special mechanical seal ensure a long service life. The integrated winding thermostats protect the motor from overload.

In conjunction with the drain master Hebefix 100 H, it provides a ready to install solution for conveying wastewater up to 176°F (80°C).

The US 73 and 103 HE/HES must not be used for pumping sewage from lavatories and urinals.



US 73 HES

Performance

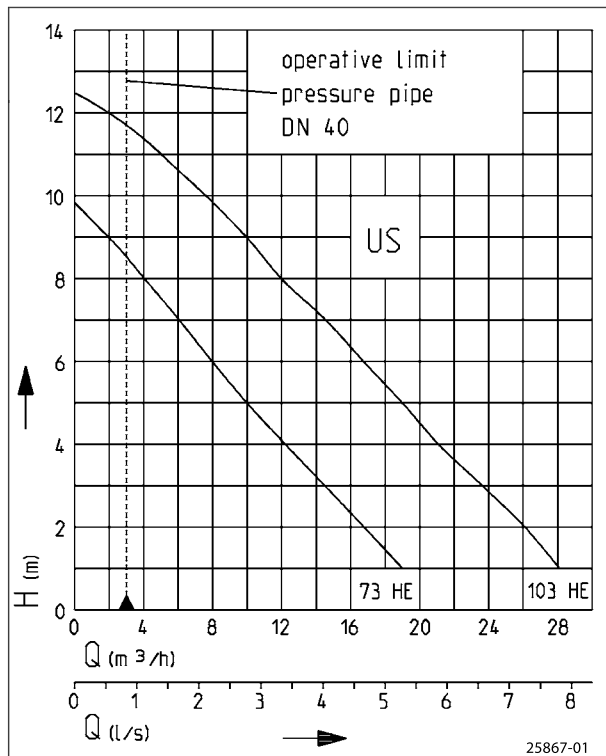

We reserve the right to change specifications without notice
 Pump performance is subject to ISO 9906 tolerances
 The minimum flow velocity in the pressure piping must be 0.7 m/s according to EN 12056.
 This data is represented in the performance curve as a limit of application.

- Safe to run dry
- 30 mm free passage
- Hot water up to 194°F (90°C)
- Controllable oil chamber
- SiC mechanical seal independent of rotation direction
- Replaceable moisture sealed cable inlet



Submersible drainage pumps for conveying hot water

Type		Max. Height x Width	Discharge branch	Free passage	Cable quality H07RN-F-	Cable length	Weight approx.	Code no.
US 73 HE	(without level control)	380 x 210 mm	1½"	30 mm	3G1.0	10 m	12.5 kg	JP 09267
US 73 HES	(with level control)	380 x 330 mm	1½"	30 mm	3G1.0	10 m	12.5 kg	JP 09264
US 103 HE	(without level control)	410 x 210 mm	1½"	30 mm	3G1.0	10 m	14.0 kg	JP 09307
US 103 HES	(with level control)	410 x 330 mm	1½"	30 mm	3G1.0	10 m	14.0 kg	JP 09308

Performance

Type	Delivery head H [m]	1	2	3	4	5	6	7	8	9	10	12
US 73 HE and HES	Flow rate Q [m³/h]	19	17	15	12	10	8	6	4	2		
US 103 HE and HES		28	26	23	21	19	17	15	12	10	8	2

Electrical Data

Type	Type of current	Voltage Volt	Motor rating kW P ₁	P ₂	RPM min. ⁻¹	Current Ampere	Motor protection	Plug
US 73 HE and HES	Single-phase current	1/N/PE~230	0.83	0.50	2510	3.9	integrated	Safety plug
US 103 HE and HES	Single-phase current	1/N/PE~230	1.37	0.98	2700	6.0	integrated	Safety plug

Single pump installation with GR

US 73 + 103 sump area with GR 40 min. 40 x 65 cm
US 73 + 103 sump area without GR min. 40 x 40 cm (without illustration)

25865-07

In case of installation beneath the backpressure level the pressure tube must be taken in a loop over the local backup level acc. to EN 12056. Besides, it must be secured with a EN 12050-4-proofed swing-type check valve. Additionally we recommend an alarm system.

Duplex pump installation

US 73 + 103 sump area without GR min. 40 x 80 cm
US 73 + 103 sump area with GR 40 min. 65 x 80 cm (without illustration)

Suspend control unit in a dry room.

25642-03

↑ Notice of min. distance!

In accordance with DIN EN 12056-4 Abs. 5.1, it has a built-in automatic spare pump or a double attachment included, which ensures that sewage drainage is not interrupted.

Accessories

				Code no.	US 73 HE	US 73 HES	US 103 HE	US 103 HES
	①	Elbow ball check valve 1½" (DN 40), PN 6 DIN EN 12050-4	H 170 B 125 D 1½"	JP 22442	•	•	•	•
		Swing-type check valve for hot water 1½" (DN 40)	H 80 B 85 D 1½"	JP 28825	•	•	•	•
	②	Stop valve 1½" (DN 40), PN 16	H 125 B max. 60 D 1½"	JP 11837	•	•	•	•
	③	Elbow 1½"		JP 17894	•	•	•	•
	④	Alarm system with submersible ball contact switch, separate, mains-dependent, with potential-free contact and 3 m cable		JP 16723		•		•
		Alarm system ditto , with 9.5 m cable		JP 24434		•		•
		Alarm system AW 3 for washing-machines with submersible ball contact switch with 3 m cable, separate, mains-dependent		JP 25090	•	•	•	•
		Alarm system AW 10 for washing-machines ditto, with 9.5 m cable		JP 25091	•	•	•	•
 	⑤	Level controls for single units (see NE level controls for description)						
		NE 1A H Single-phase current with submersible ball contact switch 3.0 m and alarm		JP 24766	•		•	
		NE 2A H Single-phase current with submersible ball contact switch 9.5 m and alarm		JP 24767	•		•	
		Counterweight (1 piece)		JP 17541	•		•	
		Separate level controls for duplex units (see section on Level controls for description)						
		BD 00E Single-phase current		JP 00482	•		•	
		Submersible switch pack BH with 3 submersible ball contact switches with 9.5 m cable and fixing device		JP 24768	•		•	
		Submersible switch pack BHmG with 3 submersible ball contact switches with 9.5 m cable and counterweight		JP 24769	•		•	
	⑥	Rechargeable battery for off the line operation of the alarm system		JP 07562	•	•	•	•
	⑦	Special float assembly for low switching points						
		Switching points: US 73 ON/OFF US 103 ON/OFF				•		•
		without GR 155/105 mm 185/135 mm with GR 180/130 mm 210/160 mm		JP 17424				
	⑧	Chain with 2 rings DIN 766, 2.5 m, 320 kg		JP 19189	•	•	•	•
		Chain stainless steel with 5 rings, 1 shackle, DIN 766, 2.5 m, 200 kg		JP 23986	•	•	•	•
	⑨	Shackle A 0.6		JP 13402	•	•	•	•
	⑩	Guide rail system GR 40		JP 25592	•	•	•	•

* only for single units

Technical data

Pump

Vertical, single-stage, submersible, with free inlet, volute casing with 1 1/2" (female) discharge branch, open centrifugal impeller, passage 30 mm.

Bearings

Common shaft for pump and motor mounted in ball bearings and permanently grease lubricated.

Seal

Silicon carbide mechanical seal, oil chamber and duplex rotary seal towards the motor section, safe to run dry

Motor

Submersible, without oil, motor type of enclosure IP 68, insulation class F, winding thermostat protects the motor from overload, starting via plug, automatically via mounted circuit or submersible ball contact switches.

Materials

Volute casing made of GG grey cast iron, power supply through rubber insulated flexible cable for hot water operation, terminal board lid, impeller, wear plate and strainer base made of glass-fiber reinforced plastic, motor casing and shaft made of stainless steel

Installation

Install pump vertically, if installed permanently, provide detachable connection or install with guide rail system GR 40

Scope of supply

Pump acc. to EN 12050 ready for connection with cable and safety plug

Dimensions US 73 + 103 HES (mm)

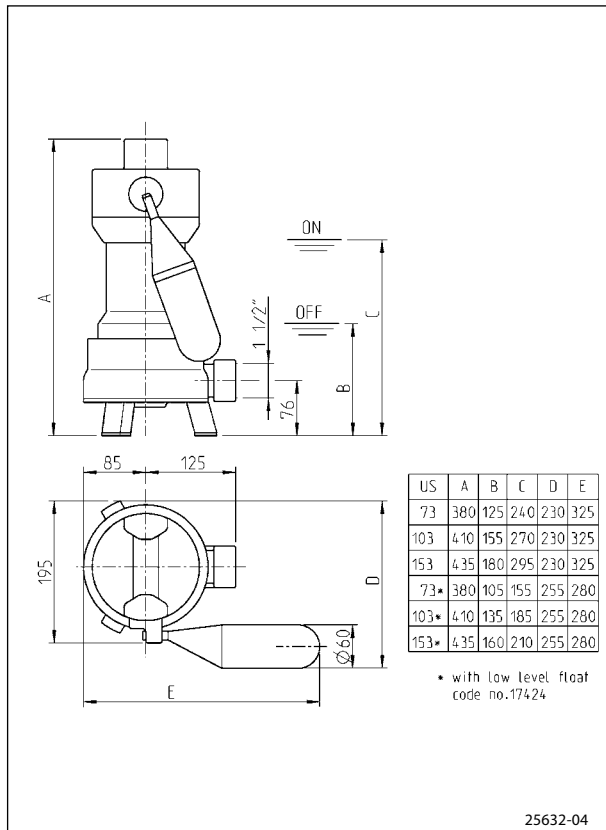

Dimensions US 73 + 103 HES (mm) with GR 40

