

Roue reculée Vortex



Caractéristiques générales

Roue reculée Vortex	
Puissance	0,37 ÷ 1,5 kW
Pôles	2 / 4
Refoulement	GAS 1 1/2" ÷ 2 1/2" Vertical GAS 2" - DN50 Horizontal DN65 - DN80 Horizontal
Passage libre	max 80 mm
Débit maxi	19.0 l/s
Hauteur maxi	17.3 m

Bloc électromécanique

Bloc électromécanique en fonte EN-GJL-250 pouvant fonctionner en mode immergé. Étanchéité garantie par 1 garniture mécanique en carbure de silicium et 1 garniture mécanique en graphite/alumine, assemblées l'une en face de l'autre et lubrifiées à l'huile. Moteur à bain d'huile.

Utilisation de la machine

Pour des applications intenses en présence de liquides biologiques chargés, égouts, eaux de pluie et d'infiltration.

Matériaux de construction

Carcasse	Fonte EN-GJL 250
Matériau roue	Fonte EN-GJL -250
Visserie	Acier inoxydable - Classe A2-70
Garniture standard	Caoutchouc - NBR
Arbre	Acier inoxydable - AISI 420
Peinture	Époxy bi-composant à base d'eau (épaisseur moyenne 80 µm)
Kit garnitures mécaniques standard	Une garniture mécanique en carbure de silicium (SiC) et une garniture mécanique en oxyde d'aluminium-carbone (AL)

Limites d'utilisation

Temp. util. maxi	40 °C
PH liquide traité	6 ÷ 11
Viscosité du liquide traité	1 mm ² /s
Prof.d'immersion maxi	20 m
Densité du liquide traité	1 Kg/dm ³
Press. acoustique maxi	70 dB
Démarrages/heure maxi	20

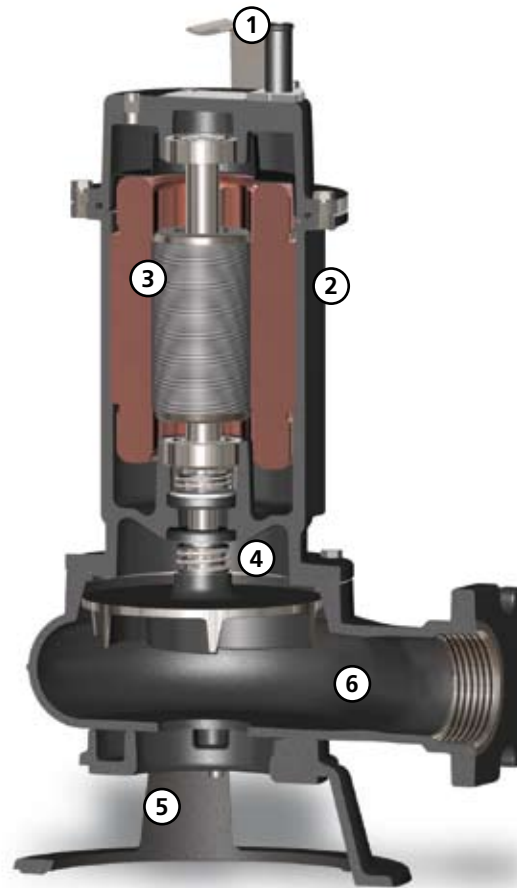

Poignée

Poignée de levage et de transport en acier inoxydable AISI 304



Structure

Corps en fonte GJL-250

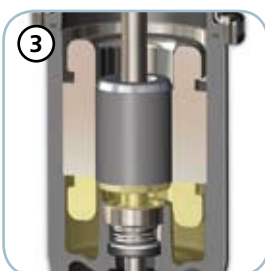

Moteur

Moteur à bain d'huile avec protections thermiques. Condensateur et protection ampérométrique logés dans le boîtier externe



Garnitures mécaniques

Une garniture mécanique en carbure de silicium (SiC) et une garniture mécanique en graphite/alumine (AL)



Orifice de refoulement / Support

Orifice de refoulement fileté et bridé pour une installation extrêmement facile. Support en fonte

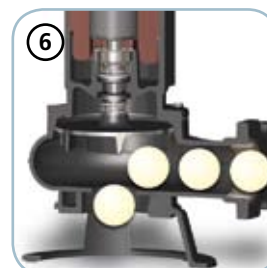

Passage libre

Large passage libre qui permet l'expulsion de corps solides et empêche le blocage de la roue

DGO

Modèles à refoulement vertical fileté GAS 1 1/2" - 2 pôles

Performances

	l/s	0	2	4	6	8
	l/min	0	120	240	360	480
	m³/h	0	7.2	14.4	21.6	28.8
① DGO 100/2/G40V B1CM(T)/50		13.6	11.2	7.9	3.5	
② DGO 150/2/G40V B1CM(T)/50		16.0	13.3	10	5.9	
③ DGO 200/2/G40V B1CM(T)/50		17.3	14.7	11.6	7.8	2.8

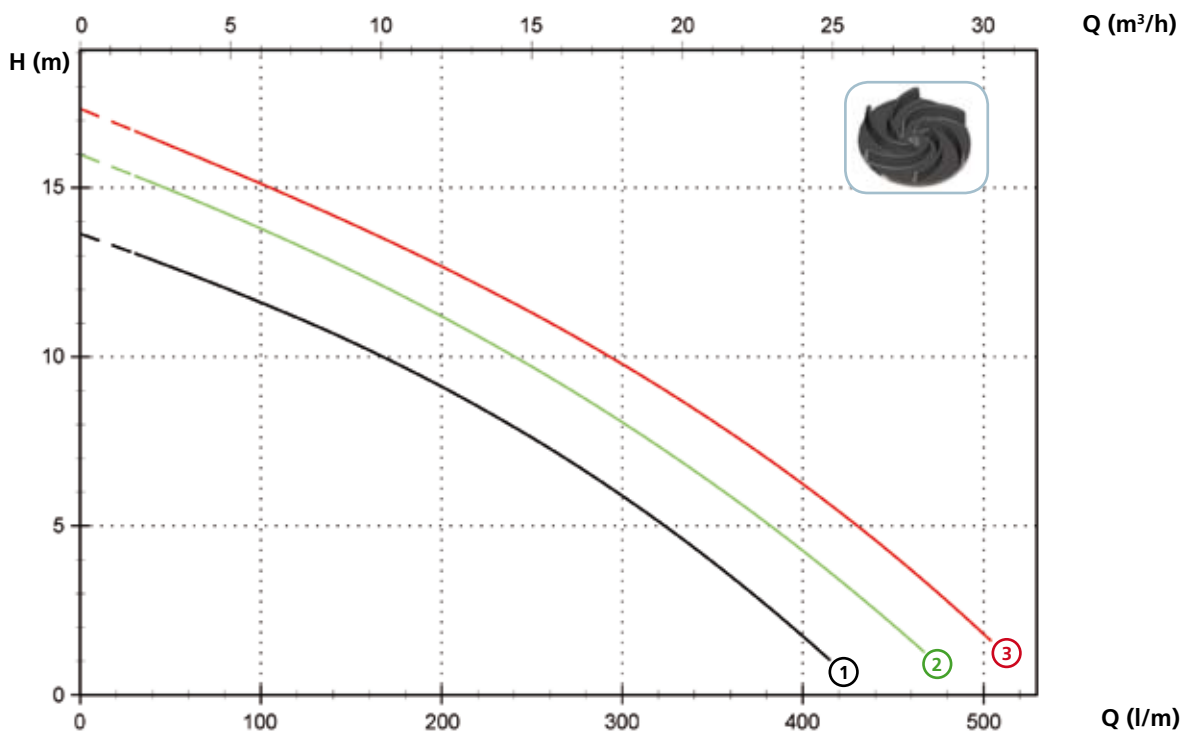

Données techniques

	V	Phases	P1 (kW)	P2 (kW)	A	Rpm	Start	Ø	Câble (*)	Passage libre
① DGO 100/2/G40V B1CM/50	230	1	-	0.88	6.4	2900	Dir	G 1 1/2"	A	40 mm
② DGO 150/2/G40V B1CM/50	230	1	-	1.1	8.3	2900	Dir	G 1 1/2"	A	40 mm
③ DGO 200/2/G40V B1CM/50	230	1	-	1.5	9.6	2900	Dir	G 1 1/2"	A	40 mm

	V	Phases	P1 (kW)	P2 (kW)	A	Rpm	Start	Ø	Câble (*)	Passage libre
① DGO 100/2/G40V B1CT/50	400	3	-	0.88	2.3	2900	Dir	G 1 1/2"	A	40 mm
② DGO 150/2/G40V B1CT/50	400	3	-	1.1	2.7	2900	Dir	G 1 1/2"	A	40 mm
③ DGO 200/2/G40V B1CT/50	400	3	-	1.5	3.6	2900	Dir	G 1 1/2"	A	40 mm

(*) A = H07RN-F 4G1 - 5 mètres avec prise shuko. Câble de 10 mètres avec prise shuko sur demande
 Attention : le câble de 10 mètres est obligatoire pour un usage externe conformément à la norme EN 60335-2-41

Modèles à refoulement vertical fileté GAS 2" - 2 pôles

Performances

l/s	0	2	4	6	8	10
l/min	0	120	240	360	480	600
m ³ /h	0	7.2	14.4	21.6	28.8	36.0

① DGO 50/2/G50V B0CM(T)/50	6.0	4.5	2.3			
② DGO 75/2/G50V B0CM(T)/50	8.6	7.2	5.1	2.3		
③ DGO 100/2/G50V B0CM(T)/50	12.2	10.1	7.9	5.8	3.6	
④ DGO 150/2/G50V B0CM(T)/50	14.2	11.8	9.5	7.3	5.1	2.7
⑤ DGO 200/2/G50V B0CM(T)/50	15.8	13.6	11.2	8.9	6.6	4.4

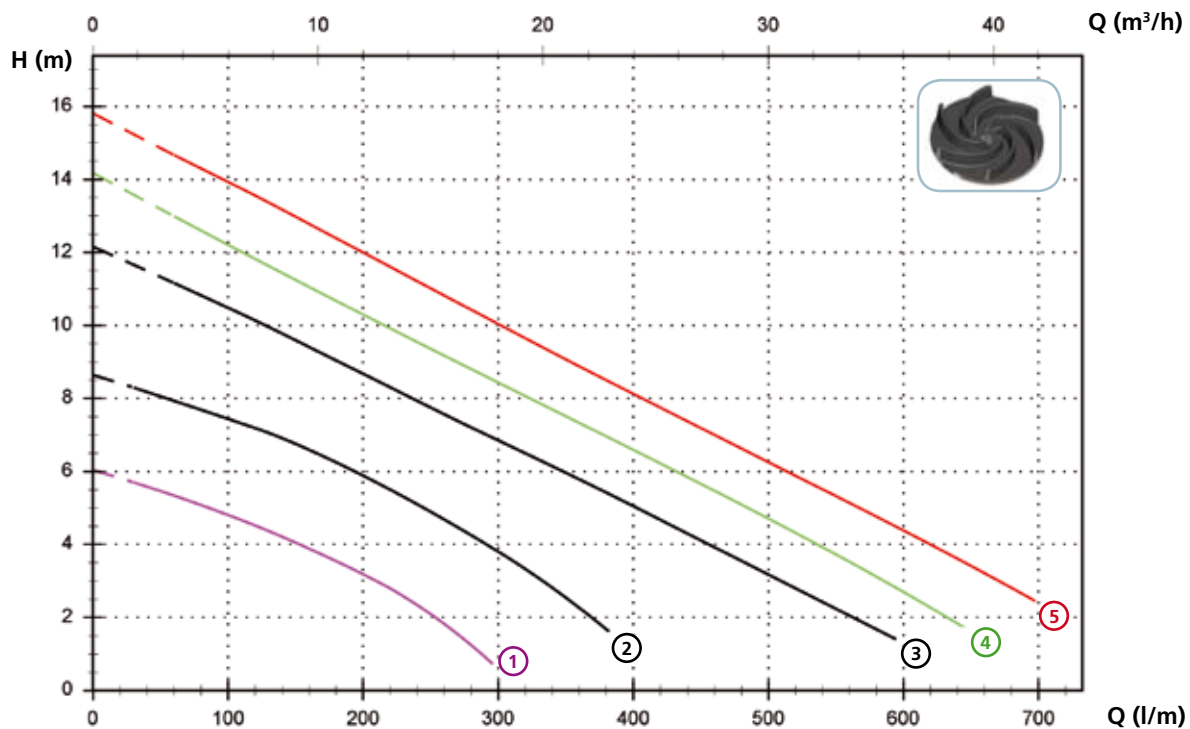

Données techniques

	V	Phases	P1 (kW)	P2 (kW)	A	Rpm	Start	Ø	Câble (*)	Passage libre
① DGO 50/2/G50V B0CM/50	230	1	-	0.37	2.9	2900	Dir	G 2"	A	40 mm
② DGO 75/2/G50V B0CM/50	230	1	-	0.55	3.9	2900	Dir	G 2"	A	40 mm
③ DGO 100/2/G50V B0CM/50	230	1	-	0.88	6.9	2900	Dir	G 2"	A	50 mm
④ DGO 150/2/G50V B0CM/50	230	1	-	1.1	8.7	2900	Dir	G 2"	A	50 mm
⑤ DGO 200/2/G50V B0CM/50	230	1	-	1.5	10.4	2900	Dir	G 2"	A	50 mm

	V	Phases	P1 (kW)	P2 (kW)	A	Rpm	Start	Ø	Câble (*)	Passage libre
① DGO 50/2/G50V B0CT/50	400	3	-	0.37	1.1	2900	Dir	G 2"	A	40 mm
② DGO 75/2/G50V B0CT/50	400	3	-	0.55	1.4	2900	Dir	G 2"	A	40 mm
③ DGO 100/2/G50V B0CT/50	400	3	-	0.88	2.3	2900	Dir	G 2"	A	50 mm
④ DGO 150/2/G50V B0CT/50	400	3	-	1.1	2.7	2900	Dir	G 2"	A	50 mm
⑤ DGO 200/2/G50V B0CT/50	400	3	-	1.5	3.6	2900	Dir	G 2"	A	50 mm

(*) A = H07RN-F 4G1 - 5 mètres avec prise shuko. Câble de 10 mètres avec prise shuko sur demande
 Attention : le câble de 10 mètres est obligatoire pour un usage externe conformément à la norme EN 60335-2-41

Modèles à refoulement horizontal fileté GAS 2" / bridé DN50 PN10-16 - 2 pôles

Performances

	l/s	0	2	4	6	8	10
	l/min	0	120	240	360	480	600
	m ³ /h	0	7.2	14.4	21.6	28.8	36.0
①	DGO 50/2/G50H A1CM(T)/50	7.8	5.6	3.3	1.0		
②	DGO 75/2/G50H A1CM(T)/50	9.0	6.9	4.7	2.6		
③	DGO 100/2/G50H A0CM(T)/50	12.7	10.6	8.2	5.7	3.1	
④	DGO 150/2/G50H A0CM(T)/50	14.4	12.1	9.7	7.3	4.8	2.2
⑤	DGO 200/2/G50H A0CM(T)/50	15.3	13.0	10.6	8.2	5.6	3.0

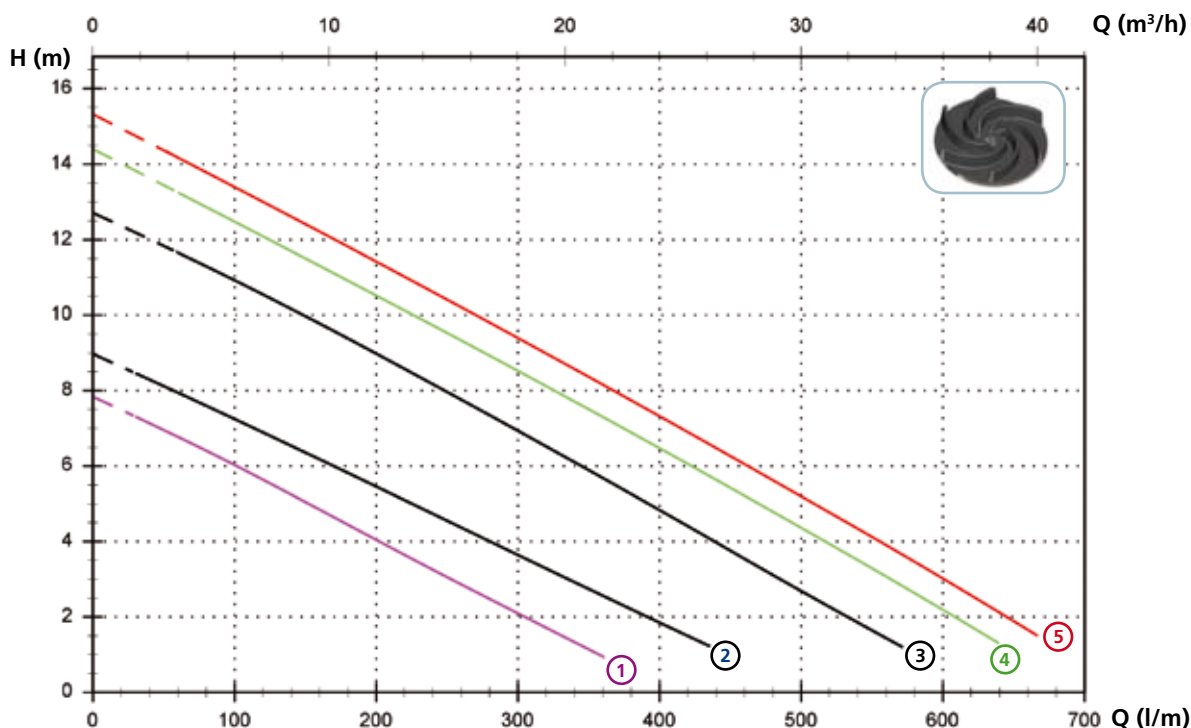

Données techniques

	V	Phases	P1 (kW)	P2 (kW)	A	Rpm	Start	Ø	Câble (*)	Passage libre	
①	DGO 50/2/G50H A1CM/50	230	1	-	0.37	2.9	2900	Dir	G 2"- DN50 PN10-16	A	40 mm
②	DGO 75/2/G50H A1CM/50	230	1	-	0.55	3.9	2900	Dir	G 2"- DN50 PN10-16	A	40 mm
③	DGO 100/2/G50H A0CM/50	230	1	-	0.88	6.5	2900	Dir	G 2"- DN50 PN10-16	A	50 mm
④	DGO 150/2/G50H A0CM/50	230	1	-	1.1	8.2	2900	Dir	G 2"- DN50 PN10-16	A	50 mm
⑤	DGO 200/2/G50H A0CM/50	230	1	-	1.5	9.3	2900	Dir	G 2"- DN50 PN10-16	A	50 mm

	V	Phases	P1 (kW)	P2 (kW)	A	Rpm	Start	Ø	Câble (*)	Passage libre	
①	DGO 50/2/G50H A1CT/50	400	3	-	0.37	1.1	2900	Dir	G 2"- DN50 PN10-16	A	40 mm
②	DGO 75/2/G50H A1CT/50	400	3	-	0.55	1.4	2900	Dir	G 2"- DN50 PN10-16	A	40 mm
③	DGO 100/2/G50H A0CT/50	400	3	-	0.88	2.3	2900	Dir	G 2"- DN50 PN10-16	A	50 mm
④	DGO 150/2/G50H A0CT/50	400	3	-	1.1	2.6	2900	Dir	G 2"- DN50 PN10-16	A	50 mm
⑤	DGO 200/2/G50H A0CT/50	400	3	-	1.5	3.6	2900	Dir	G 2"- DN50 PN10-16	A	50 mm

(*) A = H07RN-F 4G1 - 5 mètres avec prise shuko. Câble de 10 mètres avec prise shuko sur demande
 Attention : le câble de 10 mètres est obligatoire pour un usage externe conformément à la norme EN 60335-2-41

Modèles à refoulement vertical fileté GAS 2 1/2" - 2 pôles

Performances

	l/s	0	2	4	6	8	10
	l/min	0	120	240	360	480	600
	m ³ /h	0	7.2	14.4	21.6	28.8	36.0
① DGO 150/2/G65V A1CM(T)/50		8.0	7.2	6.1	4.7	3.0	
② DGO 200/2/G65V A1CM(T)/50		9.7	8.8	7.7	6.3	4.7	3.0

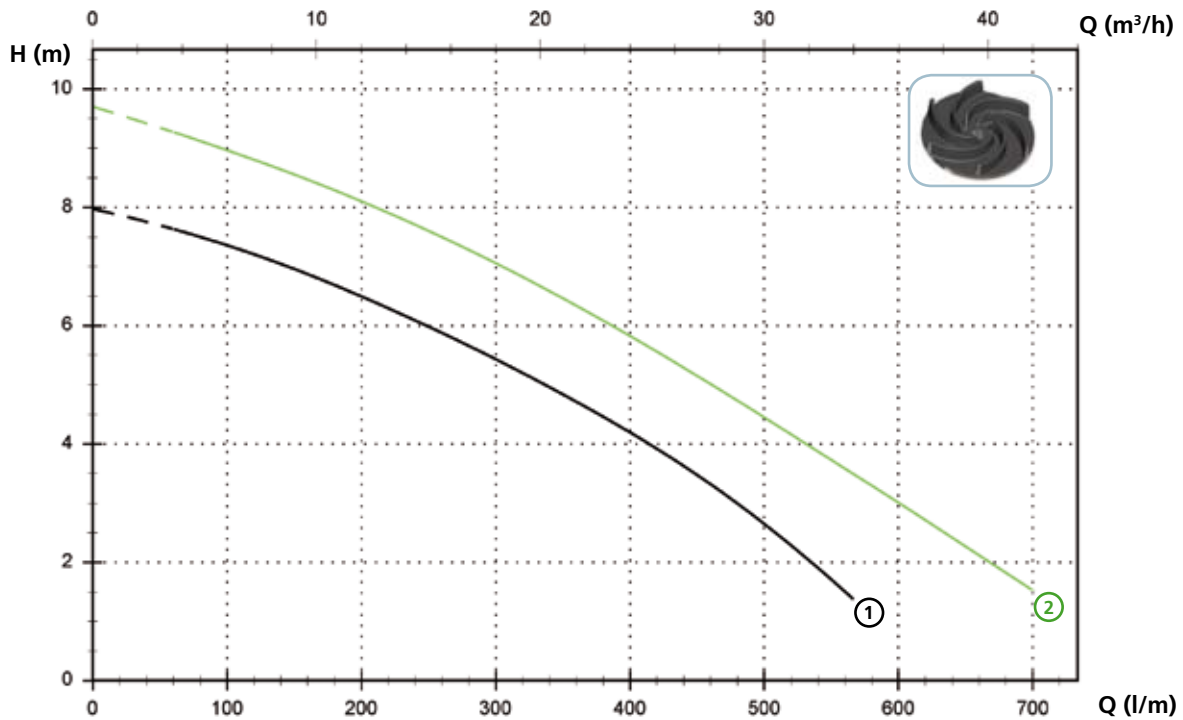

Données techniques

	V	Phases	P1 (kW)	P2 (kW)	A	Rpm	Start	Ø	Câble (*)	Passage libre
① DGO 150/2/G65V A1CM/50	230	1	-	1.1	8.2	2900	Dir	G 2 1/2"	A	65 mm
② DGO 200/2/G65V A1CM/50	230	1	-	1.5	9.9	2900	Dir	G 2 1/2"	A	65 mm

	V	Phases	P1 (kW)	P2 (kW)	A	Rpm	Start	Ø	Câble (*)	Passage libre
① DGO 150/2/G65V A1CT/50	400	3	-	1.1	2.7	2900	Dir	G 2 1/2"	A	65 mm
② DGO 200/2/G65V A1CT/50	400	3	-	1.5	3.6	2900	Dir	G 2 1/2"	A	65 mm

(*) A = H07RN-F 4G1 - 5 mètres avec prise shuko. Câble de 10 mètres avec prise shuko sur demande
 Attention : le câble de 10 mètres est obligatoire pour un usage externe conformément à la norme EN 60335-2-41

Modèles à refoulement horizontal bridé DN65 PN10-16 – 2 pôles

Performances

	l/s	0	2	4	6	8	10	12	14
	l/min	0	120	240	360	480	600	720	840
	m ³ /h	0	7.2	14.4	21.6	28.8	36.0	43.2	50.4
①	DGO 150/2/65 A1CM(T)/50	7.9	7.0	5.9	4.8	3.5	2.3		
②	DGO 200/2/65 A1CM(T)/50	9.9	9.4	8.8	7.9	6.9	5.6	4.2	2.5

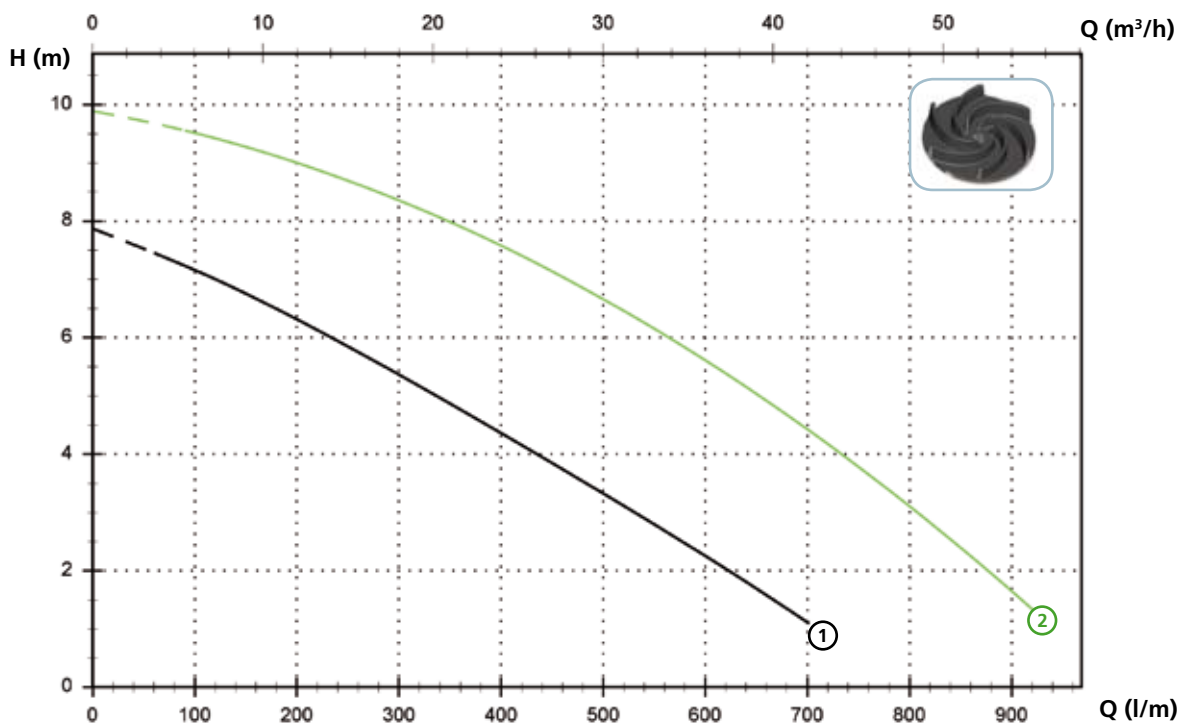

Données techniques

	V	Phases	P1 (kW)	P2 (kW)	A	Rpm	Start	Ø	Câble (*)	Passage libre	
①	DGO 150/2/65 A1CM/50	230	1	-	1.1	8.2	2900	Dir	DN65 PN10-16	A	65 mm
②	DGO 200/2/65 A1CM/50	230	1	-	1.5	9.9	2900	Dir	DN65 PN10-16	A	65 mm
	V	Phases	P1 (kW)	P2 (kW)	A	Rpm	Start	Ø	Câble (*)	Passage libre	
①	DGO 150/2/65 A1CT/50	400	3	-	1.1	2.7	2900	Dir	DN65 PN10-16	A	65 mm
②	DGO 200/2/65 A1CT/50	400	3	-	1.5	3.6	2900	Dir	DN65 PN10-16	A	65 mm

(*) A = H07RN-F 4G1 - 5 mètres avec prise shuko. Câble de 10 mètres avec prise shuko sur demande
 Attention : le câble de 10 mètres est obligatoire pour un usage externe conformément à la norme EN 60335-2-41

Modèles à refoulement horizontal bridé DN80 PN10-16 – 2 pôles

Performances

	l/s	0	2	4	6	8	10	12	14	16
	l/min	0	120	240	360	480	600	720	840	960
	m ³ /h	0	7.2	14.4	21.6	28.8	36.0	43.2	50.4	57.6
① DGO 200/2/80 A1CM(T)/50		8.4	7.9	7.2	6.4	5.5	4.5	3.6	2.6	1.7

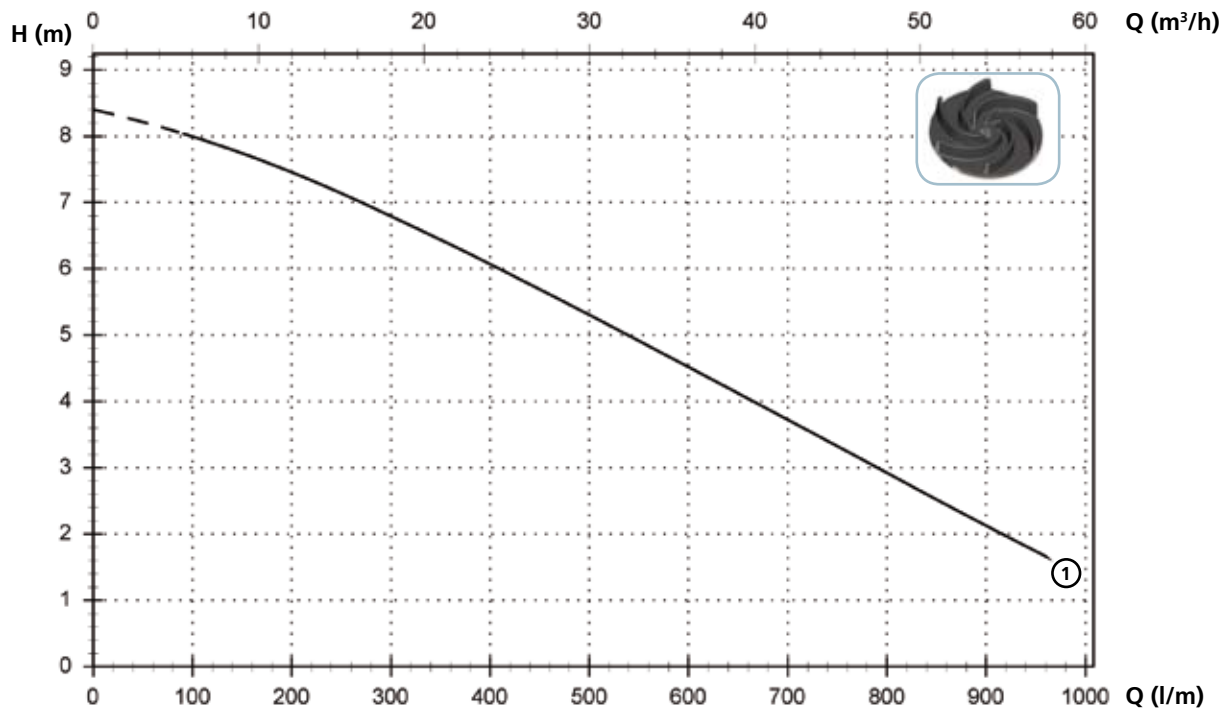

Données techniques

	V	Phases	P1 (kW)	P2 (kW)	A	Rpm	Start	Ø	Câble (*)	Passage libre
① DGO 200/2/80 A1CM/50	230	1	-	1.5	9.9	2900	Dir	DN80 PN10-16	A	80 mm
	V	Phases	P1 (kW)	P2 (kW)	A	Rpm	Start	Ø	Câble (*)	Passage libre
① DGO 200/2/80 A1CT/50	400	3	-	1.5	3.6	2900	Dir	DN80 PN10-16	A	80 mm

(*) A = H07RN-F 4G1 - 5 mètres avec prise shuko. Câble de 10 mètres avec prise shuko sur demande
 Attention : le câble de 10 mètres est obligatoire pour un usage externe conformément à la norme EN 60335-2-41

DGO

Modèles à refoulement vertical fileté GAS 2" - 4 pôles

Performances

	l/s	0	1	2	3	4	5	6	7	8	9
	l/min	0	60	120	180	240	300	360	420	480	540
	m ³ /h	0	3.6	7.2	10.8	14.4	18.0	21.6	25.2	28.8	32.4
① DGO 100/4/G50V B0CM(T)/50		5.4	5.1	4.8	4.4	4.0	3.5	3.0	2.4	1.8	1.1

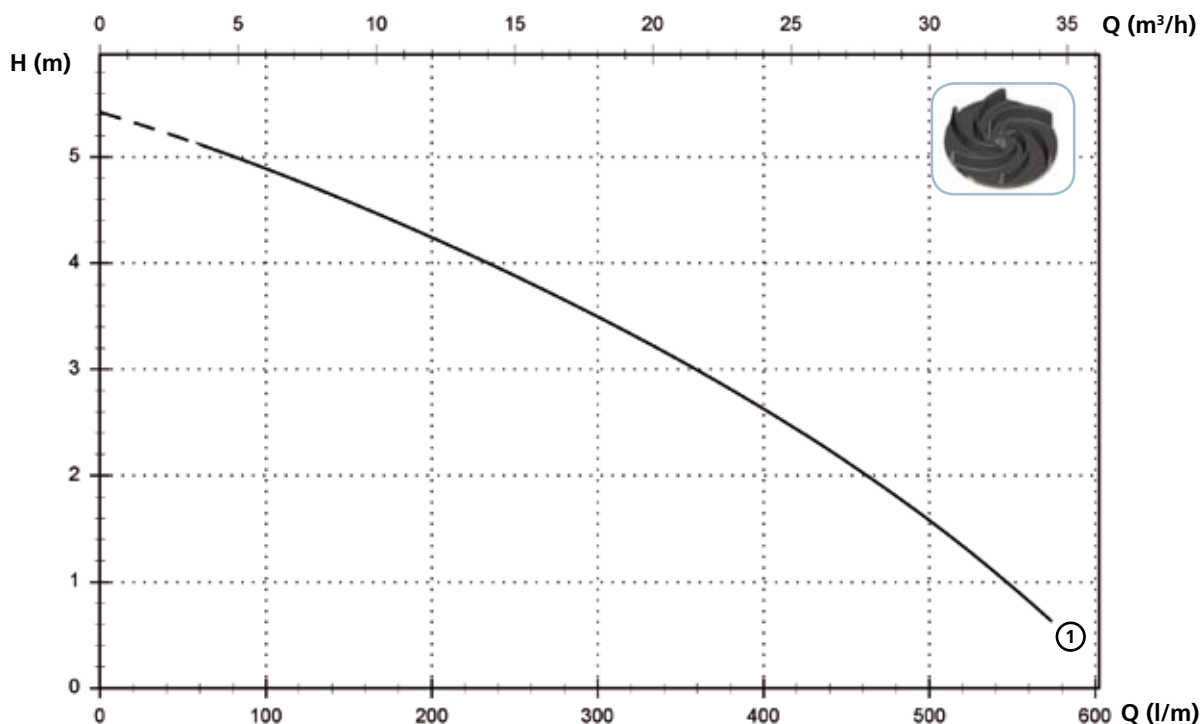

Données techniques

	V	Phases	P1 (kW)	P2 (kW)	A	Rpm	Start	Ø	Câble (*)	Passage libre
① DGO 100/4/G50V B0CM/50	230	1	-	0.7	4.5	1450	Dir	G 2"	A	45 mm

	V	Phases	P1 (kW)	P2 (kW)	A	Rpm	Start	Ø	Câble (*)	Passage libre
① DGO 100/4/G50V B0CT/50	400	3	-	0.7	1.6	1450	Dir	G 2"	A	45 mm

(*) A = H07RN-F 4G1 - 5 mètres avec prise shuko. Câble de 10 mètres avec prise shuko sur demande
 Attention : le câble de 10 mètres est obligatoire pour un usage externe conformément à la norme EN 60335-2-41

Modèles à refoulement horizontal bridé DN65 PN10-16 – 4 pôles

Performances

<i>l/s</i>	0	2	4	6	8	10	12
<i>l/min</i>	0	120	240	360	480	600	720
<i>m³/h</i>	0	7.2	14.4	21.6	28.8	36.0	43.2

① DGO 150/4/65 A0CM(T)/50	5.9	5.5	5.1	4.6	3.9	3.0	1.9
---------------------------	-----	-----	-----	-----	-----	-----	-----

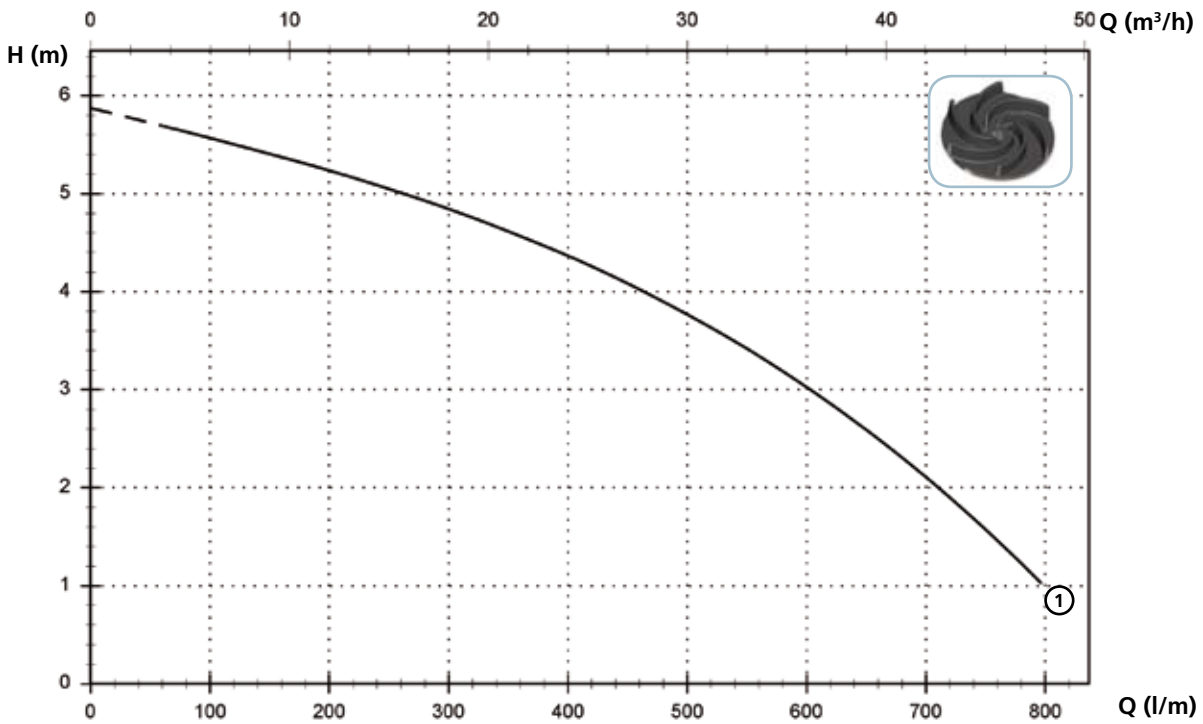

Données techniques

	V	Phases	P1 (kw)	P2 (kw)	A	Rpm	Start	Ø	Câble (*)	Passage libre
① DGO 150/4/65 A0CM/50	230	1	-	0.9	7.5	1450	Dir	DN65 PN10-16	A	45 mm

	V	Phases	P1 (kw)	P2 (kw)	A	Rpm	Start	Ø	Câble (*)	Passage libre
① DGO 150/4/65 A0CT/50	400	3	-	0.9	2.8	1450	Dir	DN65 PN10-16	A	45 mm

(*) A = H07RN-F 4G1 - 5 mètres avec prise shuko. Câble de 10 mètres avec prise shuko sur demande
 Attention : le câble de 10 mètres est obligatoire pour un usage externe conformément à la norme EN 60335-2-41

DGO

Modèles à refoulement horizontal bridé DN80 PN10-16 – 4 pôles

Performances

l/s	0	2	4	6	8	10	12	14	16	18
l/min	0	120	240	360	480	600	720	840	960	1080
m ³ /h	0	7.2	14.4	21.6	28.8	36.0	43.2	50.4	57.6	64.8

① DGO 150/4/80 A0CM(T)/50	5.4	5.1	4.7	4.3	3.8	3.4	2.8	2.3	1.7	1.1
---------------------------	-----	-----	-----	-----	-----	-----	-----	-----	-----	-----

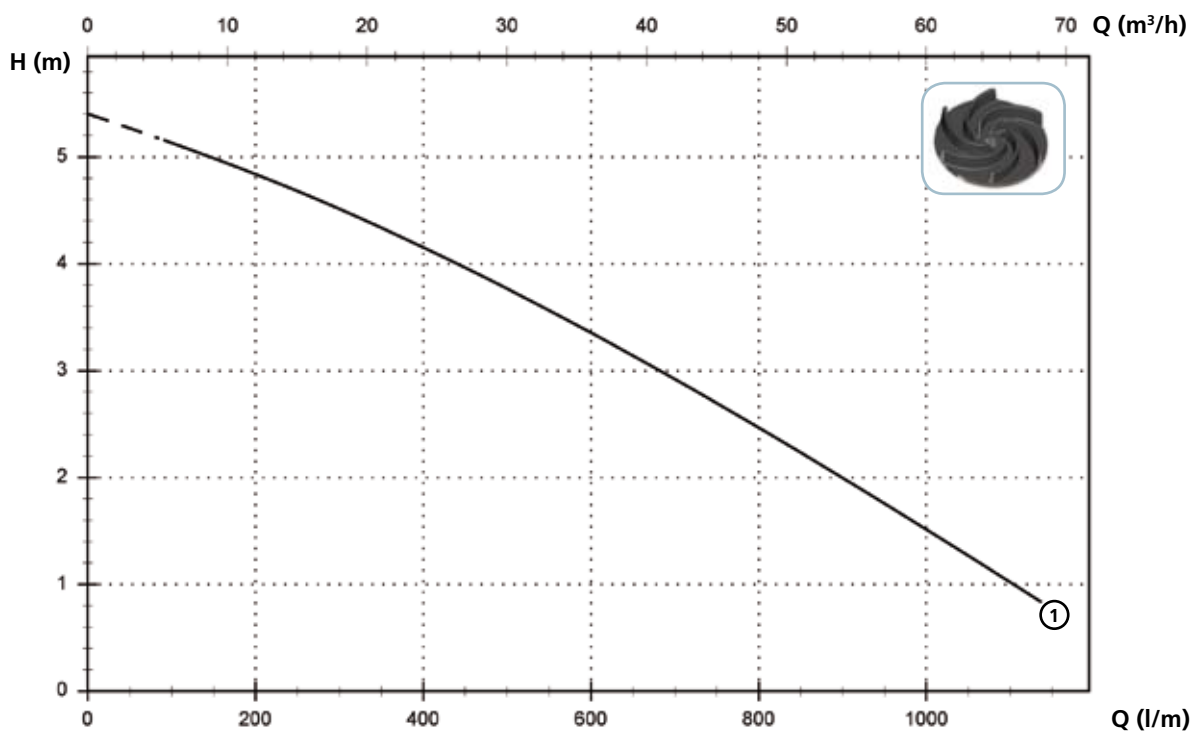

Données techniques

	V	Phases	P1 (kW)	P2 (kW)	A	Rpm	Start	Ø	Câble (*)	Passage libre
① DGO 150/4/80 A0CM/50	230	1	-	0.9	7.5	1450	Dir	DN80 PN10-16	A	60 mm
① DGO 150/4/80 A0CT/50	400	3	-	0.9	2.8	1450	Dir	DN80 PN10-16	A	60 mm

(*) A = H07RN-F 4G1 - 5 mètres avec prise shuko. Câble de 10 mètres avec prise shuko sur demande
 Attention : le câble de 10 mètres est obligatoire pour un usage externe conformément à la norme EN 60335-2-41

Versions disponibles

(Légende des versions en page 16)

	Versions disponibles											Refroidissement				Kit garnitures				
	N A E	T	T C	T C D	T C D T	T C D G T	T C G	T C S T	T C S G T	T S	T R	T R G	N	CC CCE	FT	C G F T	2SIC	SICM	SICAL	2SICAL
DGO 100/2/G40V B1CM/50		●						●	●			●							●	
DGO 150/2/G40V B1CM/50		●						●	●			●							●	
DGO 200/2/G40V B1CM/50		●						●	●			●							●	
DGO 100/2/G40V B1CT/50	●											●							●	
DGO 150/2/G40V B1CT/50	●											●							●	
DGO 200/2/G40V B1CT/50	●											●							●	
DGO 50/2/G50V B0CM/50		●						●	●			●							●	
DGO 75/2/G50V B0CM/50		●						●	●			●							●	
DGO 100/2/G50V B0CM/50		●						●	●			●							●	
DGO 150/2/G50V B0CM/50		●						●	●			●							●	
DGO 200/2/G50V B0CM/50		●						●	●			●							●	
DGO 50/2/G50V B0CT/50	●											●							●	
DGO 75/2/G50V B0CT/50	●											●							●	
DGO 100/2/G50V B0CT/50	●											●							●	
DGO 150/2/G50V B0CT/50	●											●							●	
DGO 200/2/G50V B0CT/50	●											●							●	
DGO 50/2/G50H A1CM/50		●						●	●			●							●	
DGO 75/2/G50H A1CM/50		●						●	●			●							●	
DGO 100/2/G50H A0CM/50		●						●	●			●							●	
DGO 150/2/G50H A0CM/50		●						●	●			●							●	
DGO 200/2/G50H A0CM/50		●						●	●			●							●	
DGO 50/2/G50H A1CT/50	●											●							●	
DGO 75/2/G50H A1CT/50	●											●							●	
DGO 100/2/G50H A0CT/50	●											●							●	
DGO 150/2/G50H A0CT/50	●											●							●	
DGO 200/2/G50H A0CT/50	●											●							●	
DGO 150/2/G65V A1CM/50		●						●	●			●							●	
DGO 200/2/G65V A1CM/50		●						●	●			●							●	
DGO 150/2/G65V A1CT/50	●											●							●	
DGO 200/2/G65V A1CT/50	●											●							●	
DGO 150/2/65 A1CM/50		●						●	●			●							●	
DGO 200/2/65 A1CM/50		●						●	●			●							●	
DGO 150/2/65 A1CT/50	●											●							●	
DGO 200/2/65 A1CT/50	●											●							●	
DGO 200/2/80 A1CM/50		●						●	●			●							●	
DGO 200/2/80 A1CT/50	●											●							●	
DGO 100/4/G50V B0CM/50		●						●	●			●							●	
DGO 100/4/G50V B0CT/50	●											●							●	
DGO 150/4/65 A0CM/50		●						●	●			●							●	
DGO 150/4/65 A0CT/50	●											●							●	
DGO 150/4/80 A0CM/50		●						●	●			●							●	
DGO 150/4/80 A0CT/50	●											●							●	

DGO

Dimensions d'encombrement et poids

Modèles à refoulement vertical

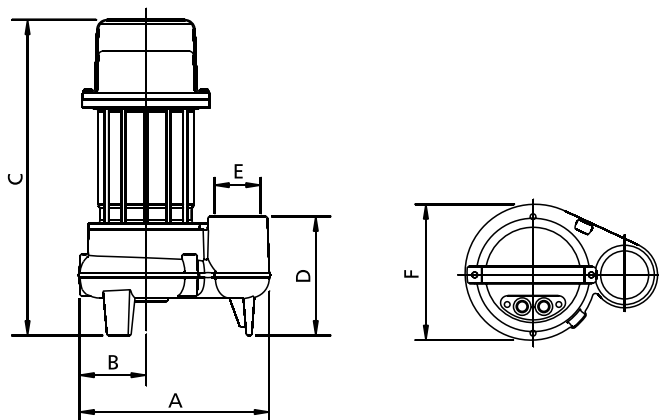

	A	B	C	D	E	F	kg
DGO 100/2/G40V B1CM(T)/50	260	100	440	125	G 1 1/2"	205	18
DGO 150/2/G40V B10CM(T)/50	260	100	440	125	G 1 1/2"	205	19
DGO 200/2/G40V B1CM(T)/50	260	100	440	125	G 1 1/2"	205	20
DGO 50/2/G50V B0CM(T)/50	230	80	380	120	G 2"	165	16.5
DGO 75/2/G50V B0CM(T)/50	230	80	380	120	G 2"	165	16.5
DGO 100/2/G50V B0CM(T)/50	270	100	455	130	G 2"	205	19.5
DGO 150/2/G50V B0CM(T)/50	270	100	455	130	G 2"	205	20.5
DGO 200/2/G50V B0CM(T)/50	270	100	455	130	G 2"	205	21.5
DGO 150/2/G65V A1CM(T)/50	300	105	435	140	G 2 1/2"	210	21
DGO 200/2/G65V A1CM(T)/50	300	105	435	140	G 2 1/2"	210	22
DGO 100/4/G50V B0CM(T)/50	270	100	455	130	G 2"	205	21

Dimensions en mm

Modèles à refoulement horizontal

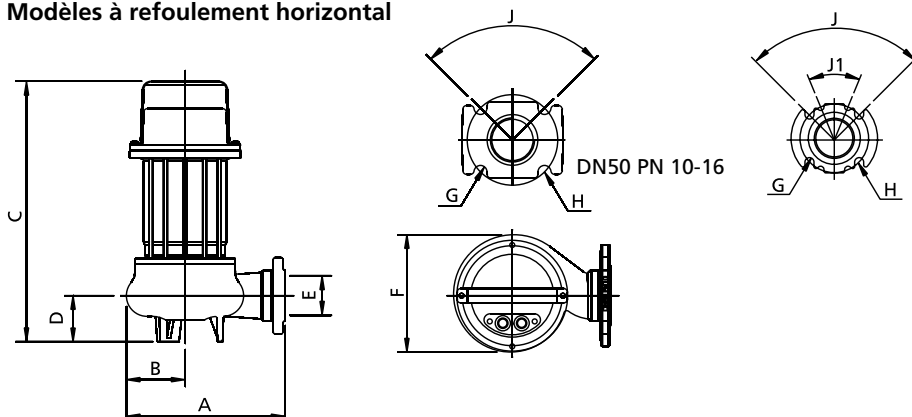

	A	B	C	D	E	F	G	H	J	J1	kg
DGO 50/2/G50H A1CM(T)/50	220	80	360	65	G 2"-DN50	160	18	125	90°	-	16.5
DGO 75/2/G50H A1CM(T)/50	220	80	360	65	G 2"-DN50	160	18	125	90°	-	16.5
DGO 100/2/G50H A0CM(T)/50	270	110	455	110	G 2"-DN50	205	18	125	90°	-	19.5
DGO 150/2/G50H A0CM(T)/50	270	110	455	110	G 2"-DN50	205	18	125	90°	-	20.5
DGO 200/2/G50H A0CM(T)/50	270	110	455	110	G 2"-DN50	205	18	125	90°	-	21.5
DGO 150/2/65 A1CM(T)/50	295	110	435	70	65	210	18	145	45°	-	22
DGO 200/2/65 A1CM(T)/50	295	110	435	70	65	210	18	145	45°	-	23
DGO 200/2/80 A1CM(T)/50	290	105	450	80	80	210	18	160	90°	45°	23
DGO 150/4/65 A0CM(T)/50	270	110	450	105	65	220	18	145	45°	-	27
DGO 150/4/80 A0CM(T)/50	270	115	480	125	80	225	18	160	90°	-	29

Dimensions en mm

Dimensions emballé

	A	B	C
DGO 100/2/G40V B1CM(T)/50	475	285	235
DGO 150/2/G40V B1CM(T)/50	475	285	235
DGO 200/2/G40V B1CM(T)/50	475	285	235
DGO 50/2/G50V B0CM(T)/50	385	225	245
DGO 75/2/G50V B0CM(T)/50	385	225	245
DGO 100/2/G50V B0CM(T)/50	475	285	235
DGO 150/2/G50V B0CM(T)/50	475	285	235
DGO 200/2/G50V B0CM(T)/50	475	285	235
DGO 50/2/G50H A1CM(T)/50	385	225	245
DGO 75/2/G50H A1CM(T)/50	385	225	245
DGO 100/2/G50H A0CM(T)/50	475	285	235
DGO 150/2/G50H A0CM(T)/50	475	285	235
DGO 200/2/G50H A0CM(T)/50	475	285	235
DGO 150/2/G65V A1CM(T)/50	475	285	235
DGO 200/2/G65V A1CM(T)/50	475	285	235
DGO 150/2/65 A1CM(T)/50	580	310	310
DGO 200/2/65 A1CM(T)/50	580	310	310
DGO 200/2/80 A1CM(T)/50	580	310	310
DGO 100/4/G50V B0CM(T)/50	475	285	235
DGO 150/4/65 A0CM(T)/50	580	310	310
DGO 150/4/80 A0CM(T)/50	580	310	310

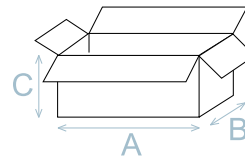

Dimensions en mm

Nbre d'articles par palette

Pour les modèles DGO 50-75, chaque palette (EUR 1000X1200 mm) peut contenir 48 articles.

Pour les modèles DGO 100-150-200, chaque palette (EUR 1000X1200 mm) peut contenir 32 articles.

Installations

