

# DRF

## Multi-channel open impeller



### General characteristics

- Multi-channel open impeller
- 0,55 ÷ 1,5 kW motor power
- 2 / 4 poles
- GAS 1 1/2" - 2" vertical  
GAS 1 1/2" DN32 - GAS 2" DN50 horizontal  
DN65 ÷ DN100
- max 50 mm free passage

### Electromechanical assembly

Electromechanical assembly in GJL-250 cast iron, for submerged operation. Seal set comprising 2 (two) silicon carbide mechanical seals assembled opposing in inspectable oil sump. Ecological dry motor. Separate pump body. Series with explosion-proof certification.

### Applications

Specifically developed for use with flammable liquids or in potentially explosive atmospheres, the DRF is used where the use of ordinary submersible electric pumps would not be possible. The main sectors of use are industrial and for the removal of landfill percolates.

### Construction materials

Case	Cast Iron EN-GJL 250
Impeller	Cast iron EN-GJL-250
Nuts and bolts	Stainless Steel - Class A2-70
Standard gasket	Rubber - NBR - VITON
Shaft	Stainless Steel - AISI 420
Set of standard mechanical seals	Two Silicon carbide mechanical seals (2SiC)

### operating limits

Maximum operating temperature	40 °C
PH of treated fluid	6 to 10 pH
Viscosity of treated fluid	1 mm <sup>2</sup> /s
Maximum immersion depth	20 m
Density of treated fluid	1 Kg/dm <sup>3</sup>
Maximum acoustic pressure	70 dB
max starts per hour	20

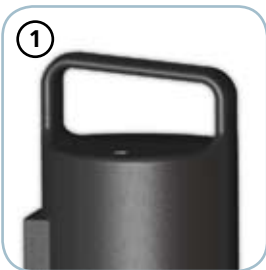
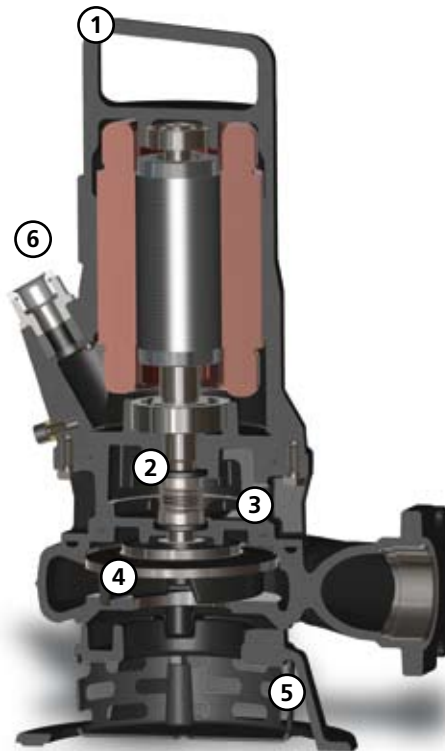

**Handle/Cable gland**

Cast iron lifting and carrying handle. The GAS thread ring-nut can be removed to fix a rigid or flexible duct to the cable gland to protect the power supply cable



**Mechanical seals**

Two mechanical seals in silicon carbide (2SiC)



**Oil sump**

Large oil sump to guarantee longer mechanical seal lifetime



**Drive shaft**

Impeller connected to the drive shaft by means of tapered coupling



**Intake strainer**

Intake strainer in tough polypropylene and cast iron feet

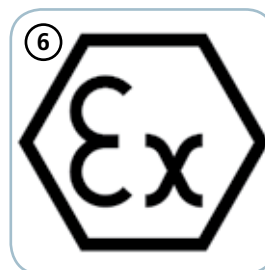

**EX**

Models with ATEX certification, suitable for installation in the presence of potentially explosive gases, powders and liquids

# DRF

## Models with vertical GAS 1 1/2" threaded delivery port - 2 poles

### Performances

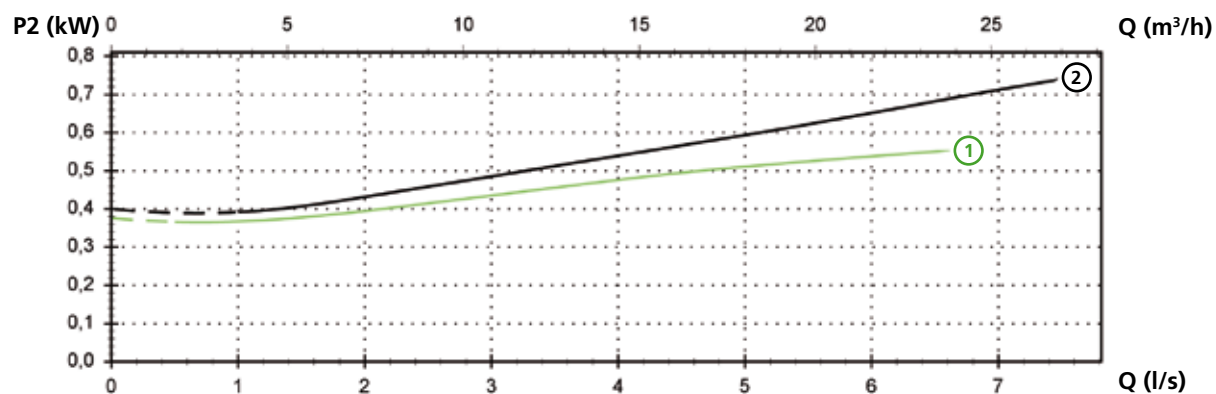
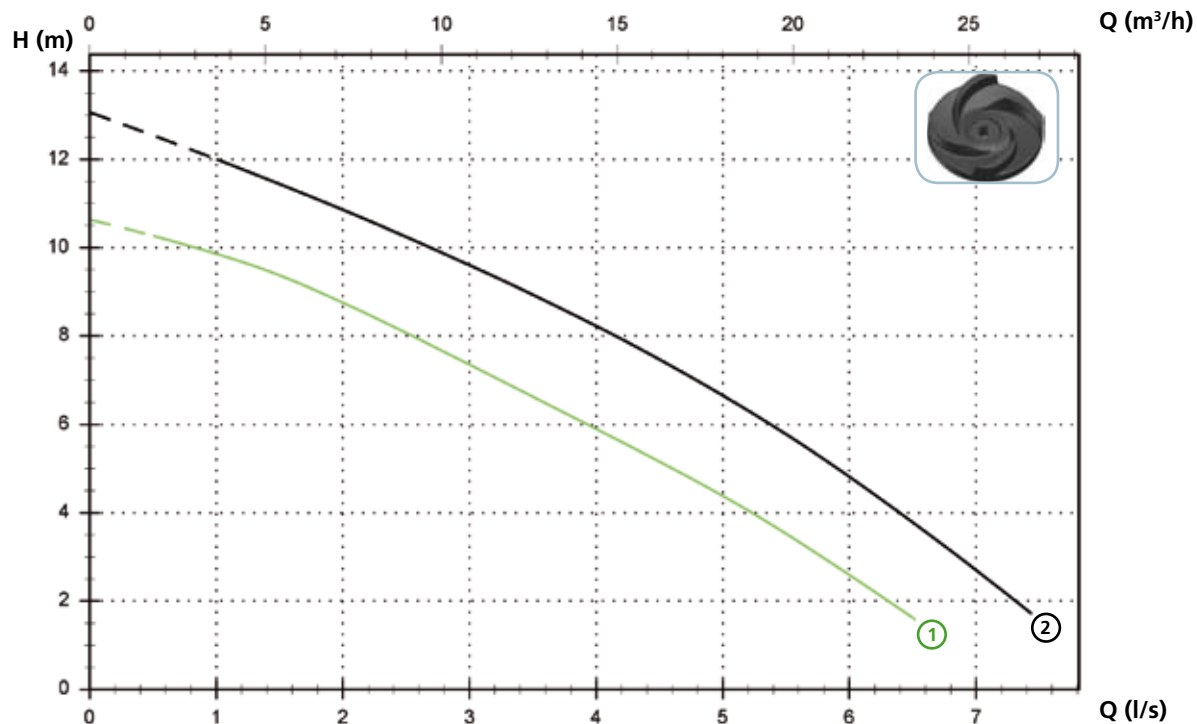

### Technical data

	V	Phases	P1 (kW)	P2 (kW)	A	Rpm	Ø	Cable (*)	Free passage
① DRF 75/2/G40V A1CM/50	230	1	0.8	0.55	3.9	2900	G 1 1/2"	A	10x30 mm
② DRF 100/2/G40V A1CM/50	230	1	1.1	0.74	4.9	2900	G 1 1/2"	A	10x30 mm

	V	Phases	P1 (kW)	P2 (kW)	A	Rpm	Ø	Cable (*)	Free passage
① DRF 75/2/G40V A1CT/50	400	3	0.8	0.55	1.5	2900	G 1 1/2"	A	10x30 mm
② DRF 100/2/G40V A1CT/50	400	3	1.1	0.74	1.9	2900	G 1 1/2"	A	10x30 mm

(\*) A = NSSHOU-J 4G1.5+2x0.75 - 10 m

**Models with horizontal GAS 1 1/2" threaded - DN32 PN6 flanged delivery port - 2 poles**

**Performances**

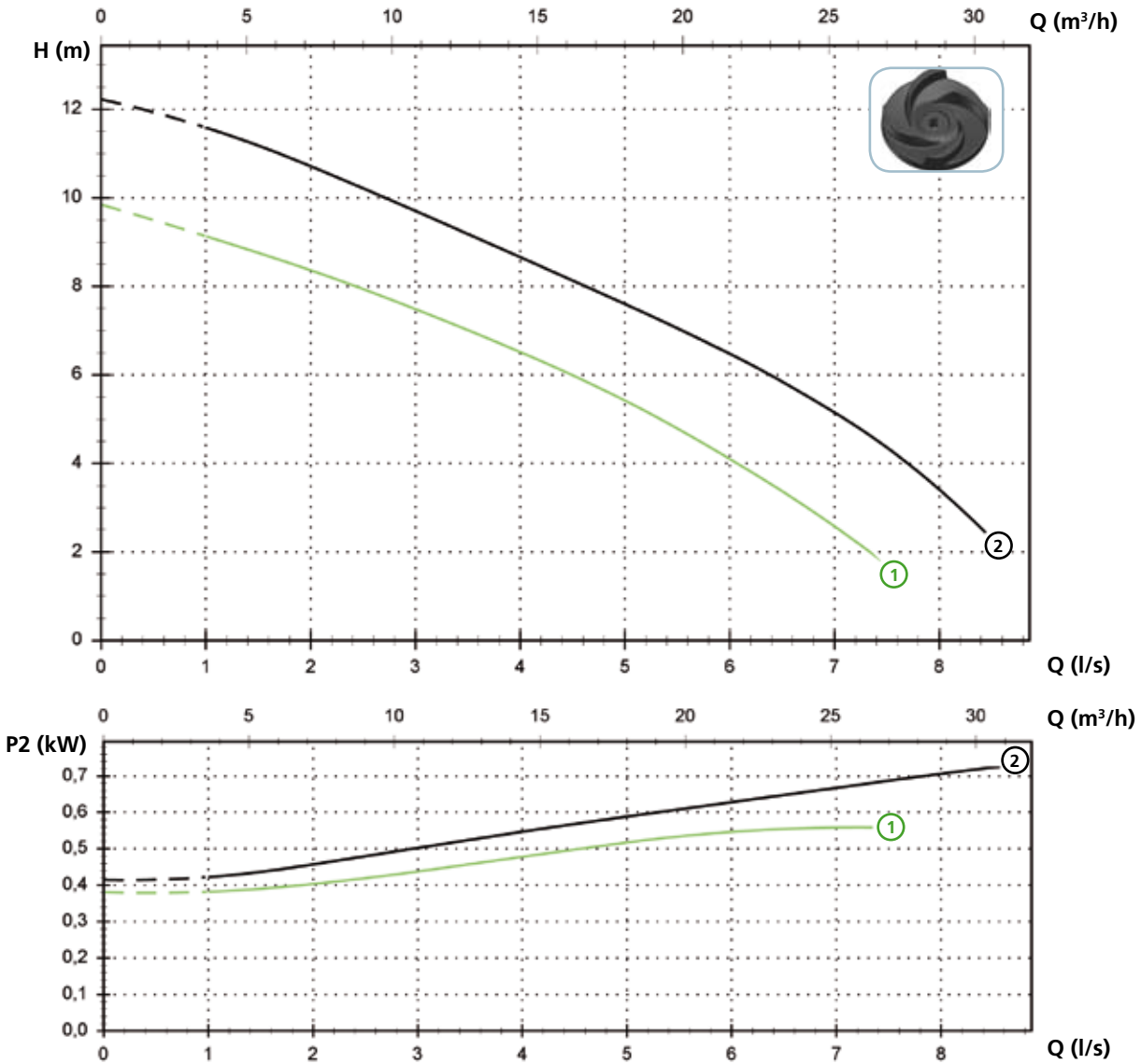

**Technical data**

	V	Phases	P1 (kW)	P2 (kW)	A	Rpm	Ø	Cable (*)	Free passage
① DRF 75/2/G40H A1CM/50	230	1	0.8	0.55	3.9	2900	G 1 1/2" - DN32 PN6	A	10x30 mm
② DRF 100/2/G40H A1CM/50	230	1	1.1	0.74	4.9	2900	G 1 1/2" - DN32 PN6	A	10x30 mm

	V	Phases	P1 (kW)	P2 (kW)	A	Rpm	Ø	Cable (*)	Free passage
① DRF 75/2/G40H A1CT/50	400	3	0.8	0.55	1.5	2900	G 1 1/2" - DN32 PN6	A	10x30 mm
② DRF 100/2/G40H A1CT/50	400	3	1.1	0.74	1.9	2900	G 1 1/2" - DN32 PN6	A	10x30 mm

(\*) A = NSSHOU-J 4G1.5+2x0.75 - 10 m

# DRF

## Models with vertical GAS 2" threaded delivery port - 2 poles

### Performances

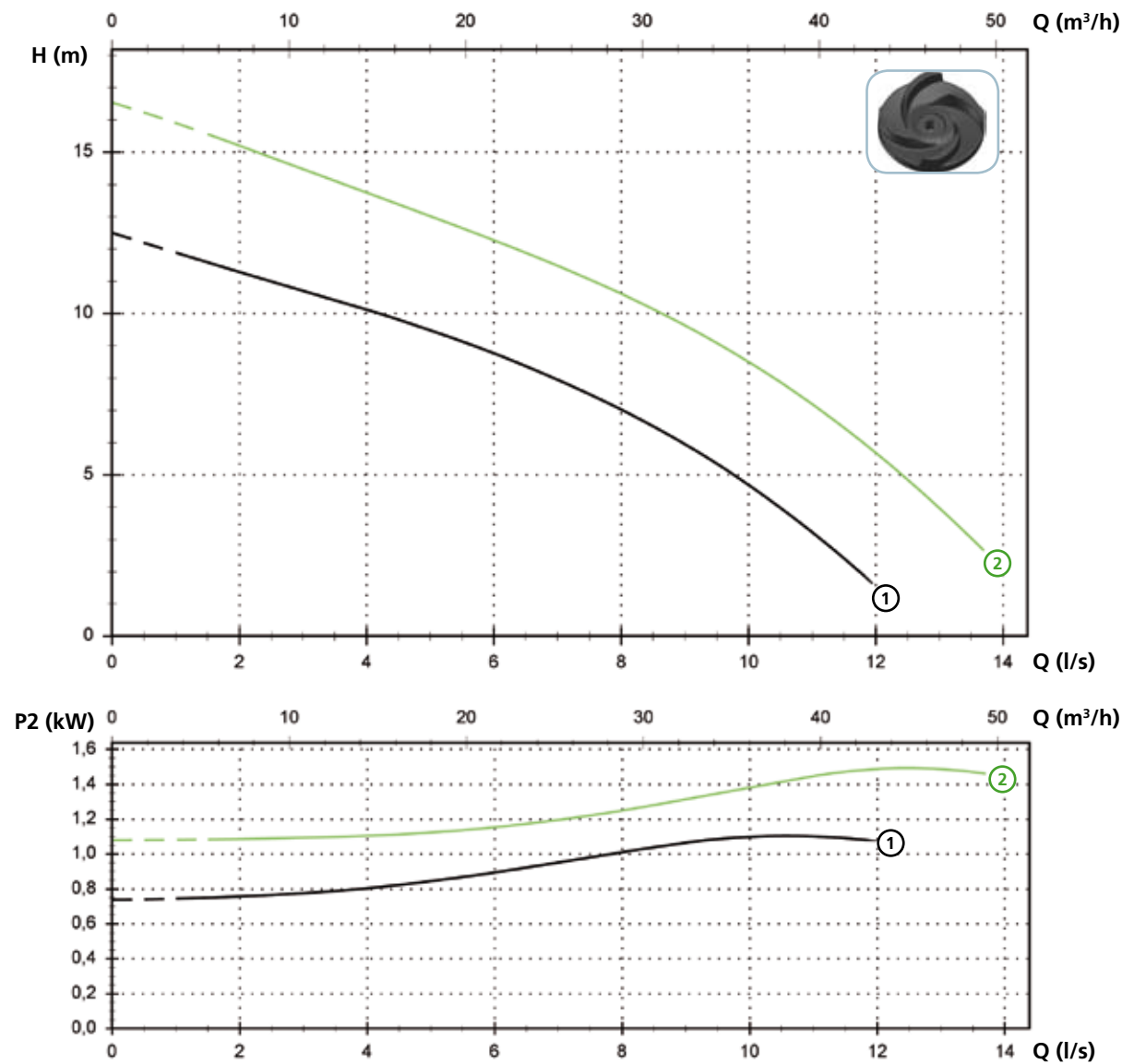

### Technical data

	V	Phases	P1 (kW)	P2 (kW)	A	Rpm	Ø	Cable (*)	Free passage
① DRF 150/2/G50V A1CM/50	230	1	1.6	1.1	7.2	2900	G 2"	A	10x30 mm
② DRF 200/2/G50V A1CM/50	230	1	2.2	1.5	9.8	2900	G 2"	A	10x30 mm

	V	Phases	P1 (kW)	P2 (kW)	A	Rpm	Ø	Cable (*)	Free passage
① DRF 150/2/G50V A1CT/50	400	3	1.7	1.1	2.9	2900	G 2"	A	10x30 mm
② DRF 200/2/G50V A1CT/50	400	3	2.1	1.5	3.7	2900	G 2"	A	10x30 mm

(\*) A = NSSHOU-J 4G1.5+2x0.75 - 10 m

**Models with horizontal GAS 2" threaded - DN50 PN10-16 flanged delivery port - 2 poles**

**Performances**

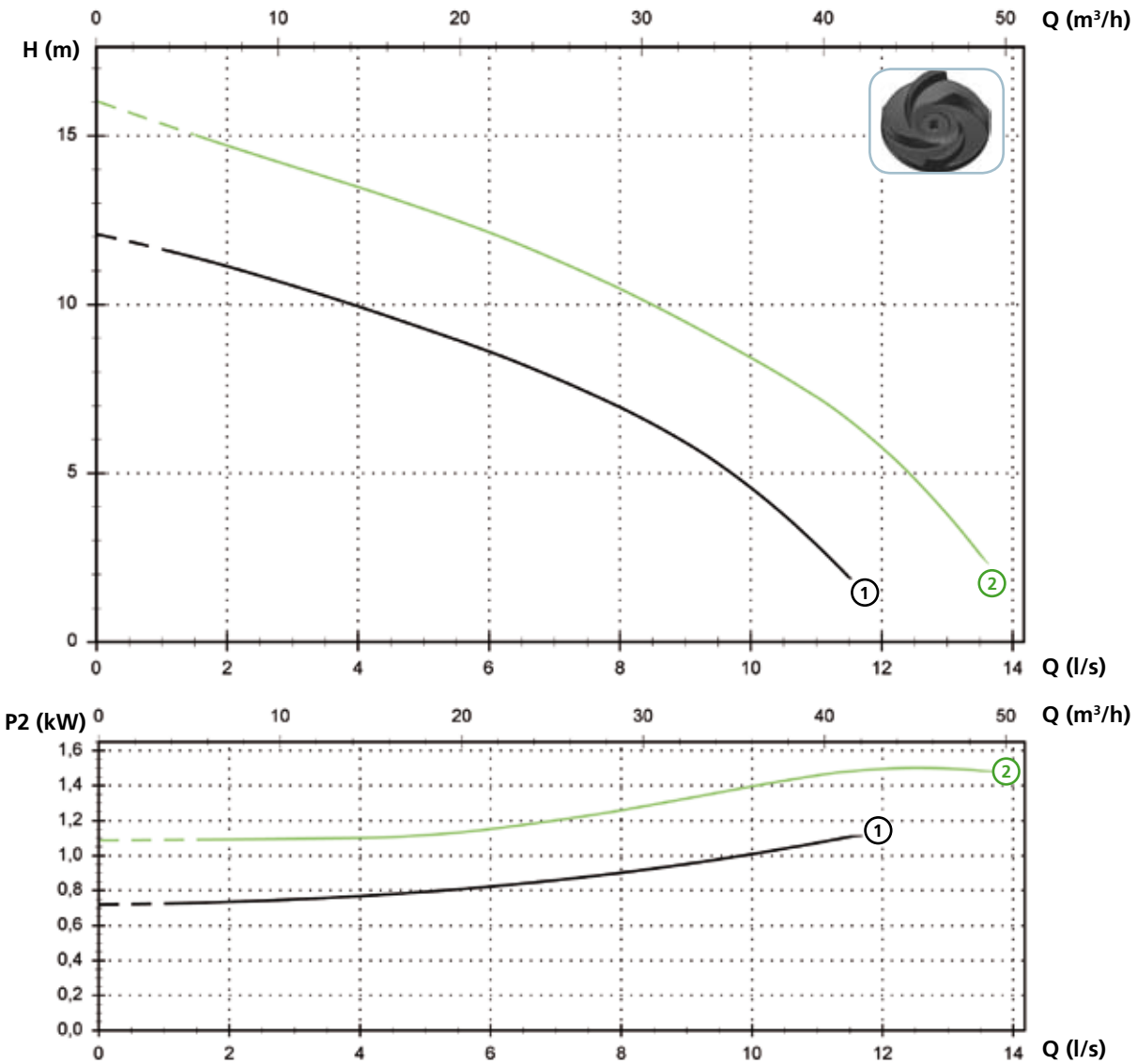

**Technical data**

		V	Phases	P1 (kW)	P2 (kW)	A	Rpm	Ø	Cable (*)	Free passage
①	DRF 150/2/G50H A1CM/50	230	1	1.6	1.1	7.2	2900	G 2"- DN50 PN10-16	A	10x30 mm
②	DRF 200/2/G50H A1CM/50	230	1	2.2	1.5	9.8	2900	G 2"- DN50 PN10-16	A	10x30 mm

		V	Phases	P1 (kW)	P2 (kW)	A	Rpm	Ø	Cable (*)	Free passage
①	DRF 150/2/G50H A1CT/50	400	3	1.7	1.1	2.9	2900	G 2"- DN50 PN10-16	A	10x30 mm
②	DRF 200/2/G50H A1CT/50	400	3	2.1	1.5	3.7	2900	G 2"- DN50 PN10-16	A	10x30 mm

(\*) A = NSSHOU-J 4G1.5+2x0.75 - 10 m

# DRF

## Models with horizontal DN65 PN10-16 flanged delivery port - 4 poles

### Performances

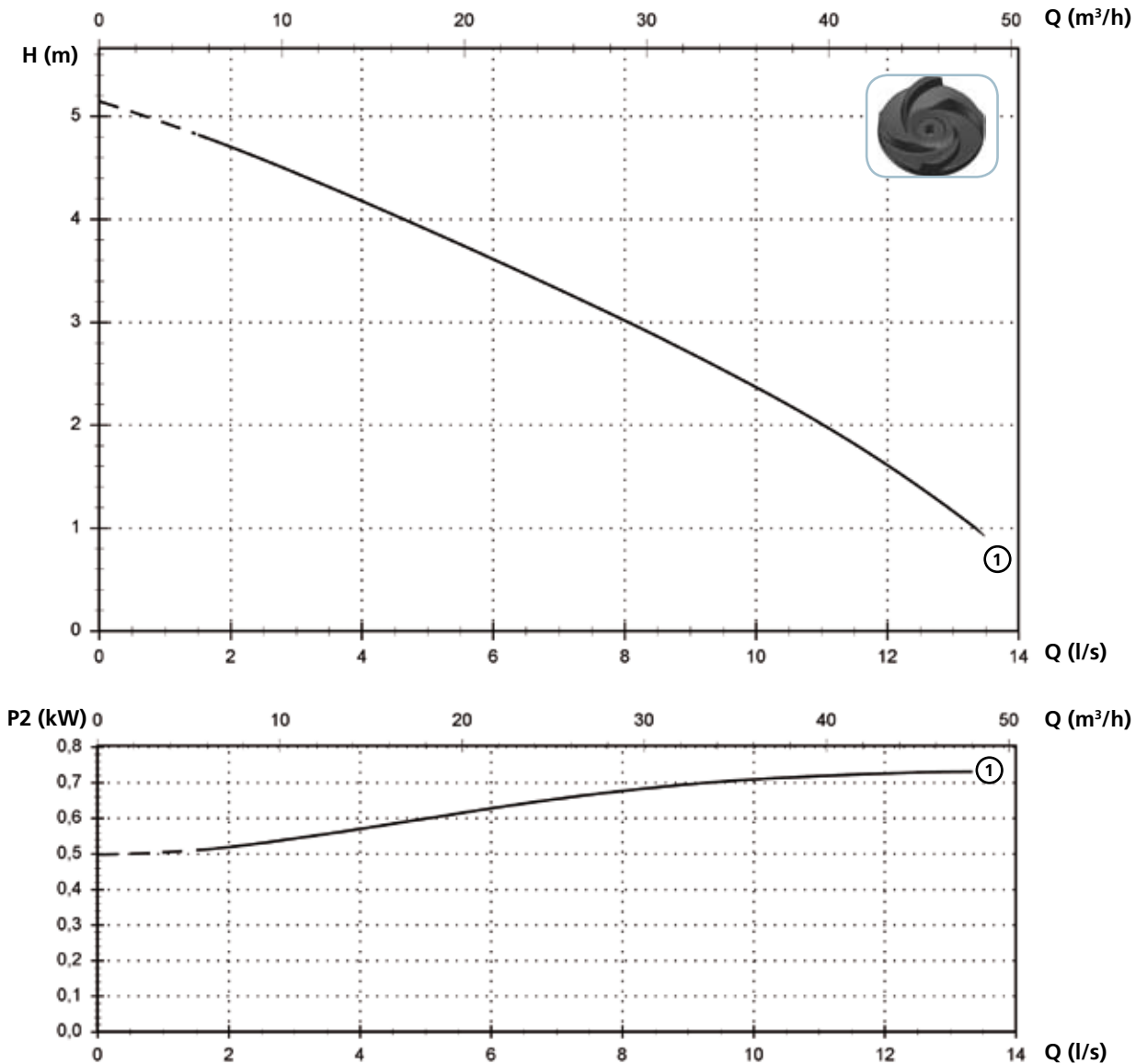

### Technical data

	V	Phases	P1 (kW)	P2 (kW)	A	Rpm	Ø	Cable (*)	Free passage
① DRF 100/4/65 A1CT/50	400	3	1.1	0.74	2.2	1450	DN65 PN10 -16	A	50 mm

(\*) A = NSSHOU-J 4G1.5+2x0.75 - 10 m

Models with horizontal DN80 PN10-16 flanged delivery port - 4 poles

Performances

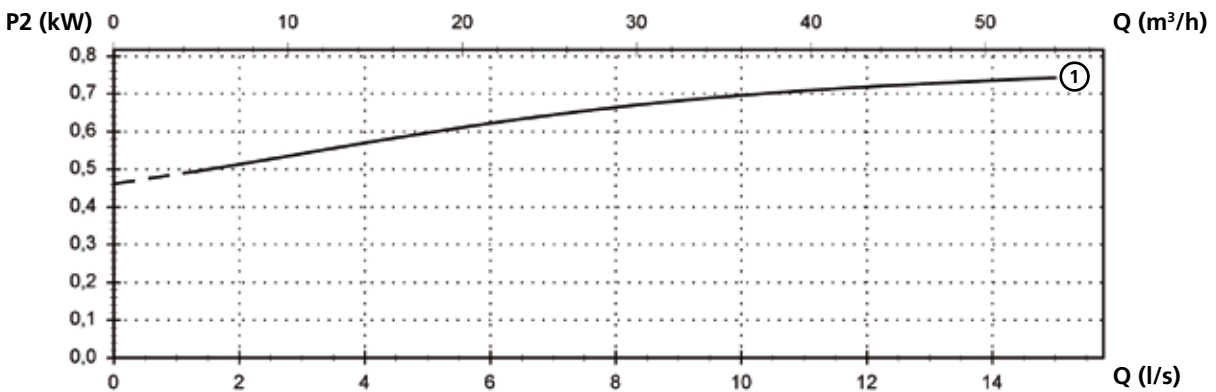
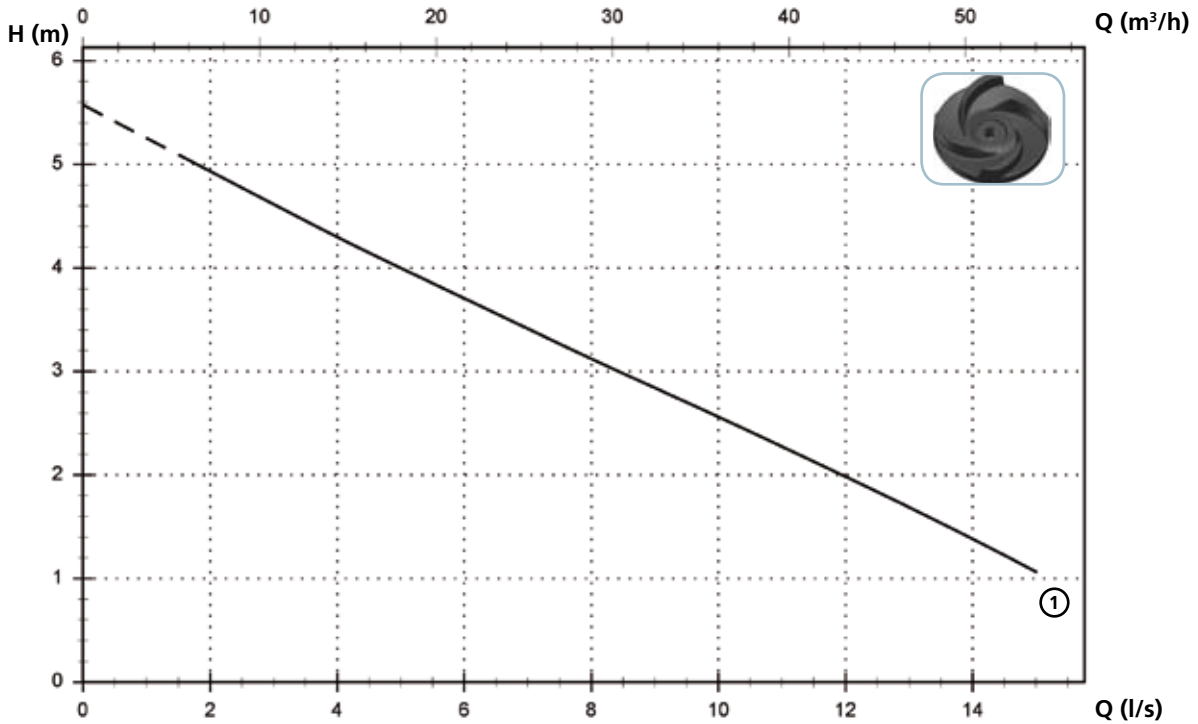

Technical data

	V	Phases	P1 (kW)	P2 (kW)	A	Rpm	Ø	Cable (*)	Free passage
① DRF 100/4/80 A1CT/50	400	3	1.1	0.74	2.2	1450	DN80 PN10-16	A	50 mm

(\*) A = NSSHOU-J 4G1.5+2x0.75 - 10 m



# DRF

## Models with horizontal DN100 PN10-16 flanged delivery port - 4 poles

### Performances

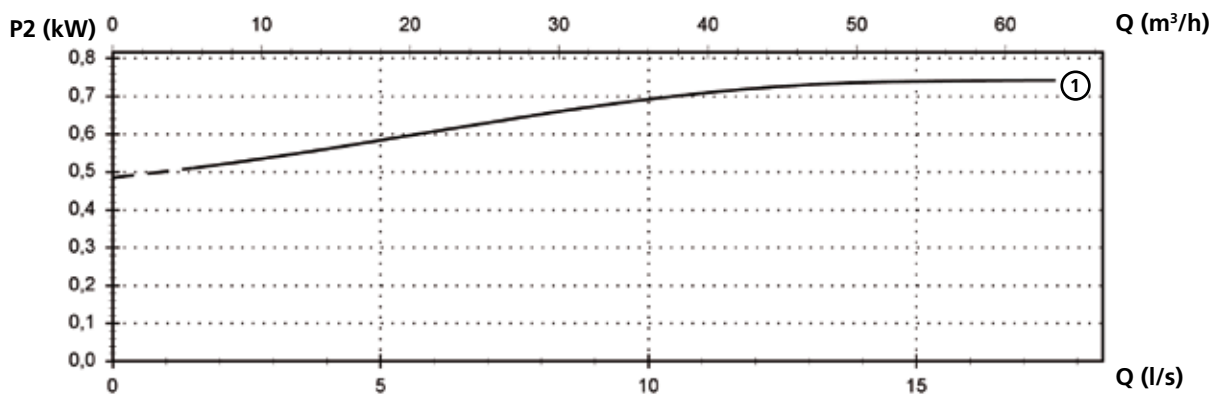
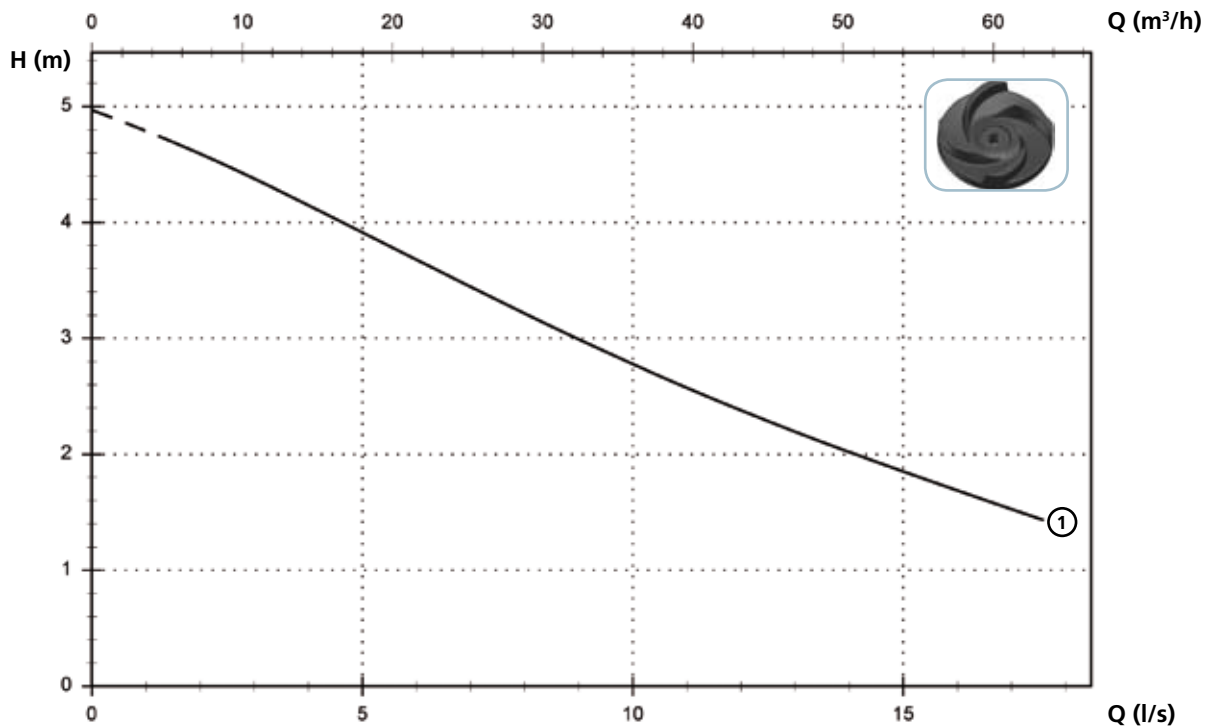

### Technical data

	V	Phases	P1 (kW)	P2 (kW)	A	Rpm	Ø	Cable (*)	Free passage
① DRF 100/4/100 A1CT/50	400	3	1.1	0.74	2.2	1450	DN100 PN10-16	A	50 mm

(\*) A = NSSHOU-J 4G1.5+2x0.75 - 10 m

**Versions available**

(Key to versions on page 15)

	Electrical variants											Cooling		Mechanical seals				
	N A E	T	T C D	T C D T	T C D G T	T C S T	T C S G T	T S	T R	T R G	F T	C G F T	N	CC	2SIC	SICM	SICAL	2SICAL
DRF 75/2/G40V A1CM/50			●										●		●			
DRF 100/2/G40V A1CM/50			●										●		●			
DRF 150/2/G50V A1CM/50			●										●		●			
DRF 200/2/G50V A1CM/50			●										●		●			
DRF 75/2/G40H A1CM/50			●										●		●			
DRF 100/2/G40H A1CM/50			●										●		●			
DRF 150/2/G50H A1CM/50			●										●		●			
DRF 200/2/G50H A1CM/50			●										●		●			
DRF 75/2/G40V A1CT/50	●												●		●			
DRF 100/2/G40V A1CT/50	●												●		●			
DRF 150/2/G50V A1CT/50	●												●		●			
DRF 200/2/G50V A1CT/50	●												●		●			
DRF 75/2/G40H A1CT/50	●												●		●			
DRF 100/2/G40H A1CT/50	●												●		●			
DRF 150/2/G50H A1CT/50	●												●		●			
DRF 200/2/G50H A1CT/50	●												●		●			
DRF 100/4/65 A1CT/50	●												●		●			
DRF 100/4/80 A1CT/50	●												●		●			
DRF 100/4/100 A1CT/50	●												●		●			

NOTE: For single phase pumps thermal protections into the winding have to be connected to the electrical panel.  
 Capacitor supplied but not connected to the pump cable.  
 The use of an electrical panel as circuit breaker housing is mandatory.  
 For installation please see use and maintenance instructions booklet.

**Overall dimensions and weights**

**Models with vertical delivery port**

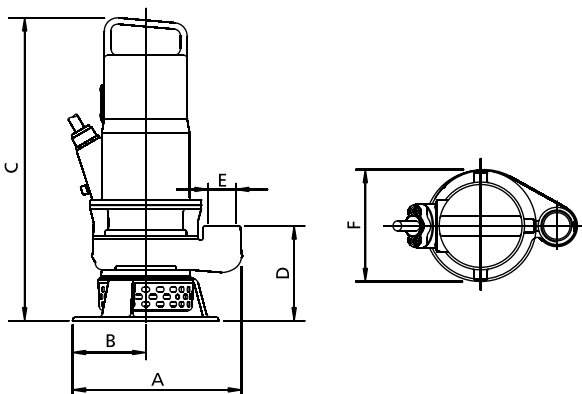

	A	B	C	D	E	F	kg
DRF 75/2/G40V A1CM(T)/50	225	80	455	145	G 1 1/2"	170	27
DRF 100/2/G40V A1CM(T)/50	225	80	455	145	G 1 1/2"	170	28
DRF 150/2/G50V A1CM(T)/50	265	100	465	165	G 2"	190	32
DRF 200/2/G50V A1CM(T)/50	265	100	465	165	G 2"	190	32

Measurements in mm

# DRF

## Models with horizontal delivery port

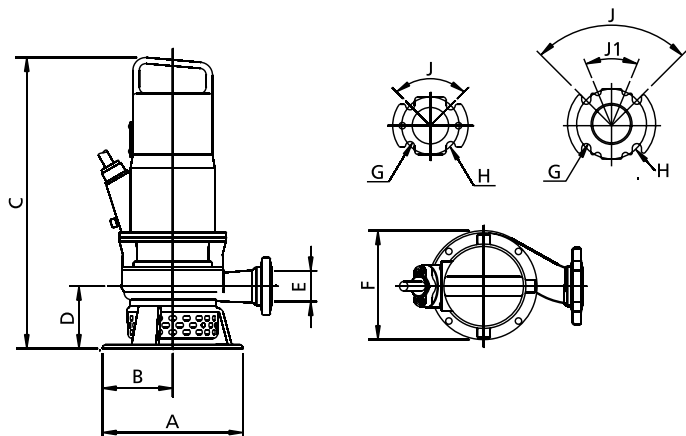

	A	B	C	D	E	F	G	H	J	J1	kg
DRF 75/2/G40H A1CM(T)/50	225	80	455	100	G 1 1/2"	170	14	90	90°	-	28
DRF 100/2/G40H A1CM(T)/50	225	80	455	100	G 1 1/2"	170	14	90	90°	-	31
DRF 150/2/G50H A1CM(T)/50	250	90	465	105	G 2"	195	18	125	90°	-	31
DRF 200/2/G50H A1CM(T)/50	250	90	465	105	G 2"	195	18	125	90°	-	32
DRF 100/4/65 A1CT/50	345	135	455	80	65	255	18	145	90°	-	41
DRF 100/4/80 A1CT/50	345	135	455	80	80	255	18	160	90°	45°	42
DRF 100/4/100 A1CT/50	430	170	475	90	100	325	18	180	45°	-	47

Measurements in mm

## Packaging dimension

	A	B	C
DRF 75/2/G40V A1CM(T)/50	580	310	310
DRF 100/2/G40V A1CM(T)/50	580	310	310
DRF 150/2/G50V A1CM(T)/50	580	310	310
DRF 200/2/G50V A1CM(T)/50	580	310	310
DRF 75/2/G40H A1CM(T)/50	580	310	310
DRF 100/2/G40H A1CM(T)/50	580	310	310
DRF 150/2/G50H A1CM(T)/50	580	310	310
DRF 200/2/G50H A1CM(T)/50	580	310	310
DRF 100/4/65 A1CT/50	725	445	415
DRF 100/4/80 A1CT/50	725	445	415
DRF 100/4/100 A1CT/50	725	445	415

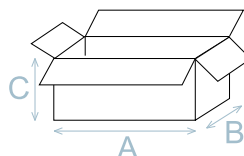

Dimension in mm

## Installations available

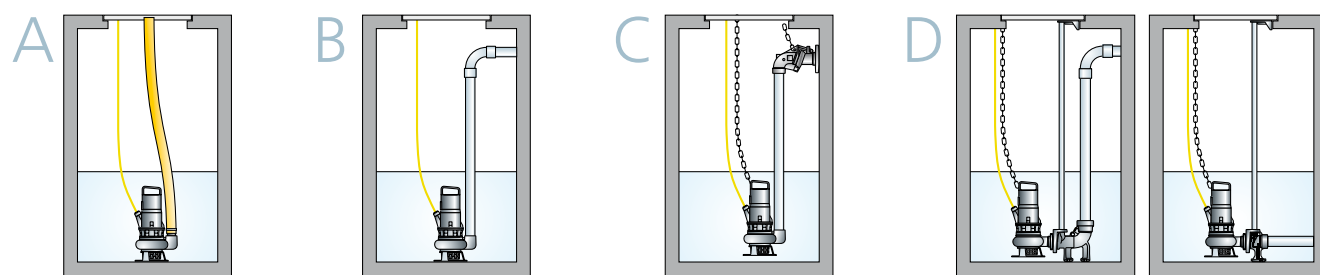

Dry installation available for specified models. Contact Custome Service for more information.